

## Kit borsa da sella stagna OUTDOOR / Sealed seat bag kit - OUTDOOR



## Simbologia

Per una lettura rapida e razionale sono stati impiegati simboli che evidenziano situazioni di massima attenzione, consigli pratici o semplici informazioni.

Prestare molta attenzione al significato dei simboli, in quanto la loro funzione è quella di non dovere ripetere concetti tecnici o avvertenze di sicurezza. Sono da considerare, quindi, dei veri e propri "promemoria".

Consultare questa pagina ogni volta che sorgeranno dubbi sul loro significato.



### Attenzione

La non osservanza delle istruzioni riportate può creare una situazione di pericolo e causare gravi lesioni personali e anche la morte.



### Importante

Indica la possibilità di arrecare danno al veicolo e/o ai suoi componenti se le istruzioni riportate non vengono eseguite.



### Note

Fornisce utili informazioni sull'operazione in corso.

## Riferimenti

I particolari evidenziati in grigio e riferimento numerico (Es. ①) rappresentano l'accessorio da installare e gli eventuali componenti di montaggio forniti a kit.

I particolari con riferimento alfabetico (Es. A) rappresentano i componenti originali presenti sul motoveicolo.

Tutte le indicazioni destro o sinistro si riferiscono al senso di marcia del motociclo.

## Avvertenze generali



### Attenzione

Le operazioni riportate nelle pagine seguenti devono essere eseguite da un tecnico specializzato o da un'officina autorizzata DUCATI.



### Attenzione

Le operazioni riportate nelle pagine seguenti se non eseguite a regola d'arte possono pregiudicare la sicurezza del pilota.



### Note

Documentazione necessaria per eseguire il montaggio del Kit è il MANUALE OFFICINA, relativo al modello di moto in vostro possesso.



### Note

Nel caso fosse necessaria la sostituzione di un componente del kit consultare la tavola ricambi allegata.

## Symbols

To allow quick and easy consultation, this manual uses graphic symbols to highlight situations in which maximum care is required, as well as practical advice or information.

Pay attention to the meaning of the symbols since they serve to avoid repeating technical concepts or safety warnings throughout the text. The symbols should therefore be seen as real reminders. Please refer to this page whenever in doubt as to their meaning.



### Warning

Failure to follow these instructions might give rise to a dangerous situation and provoke severe personal injuries or even death.



### Caution

Failure to follow these instructions might cause damages to the vehicle and/or its components.



### Notes

Useful information on the procedure being described.

## References

Parts highlighted in grey and with a numeric reference (Example ①) are the accessory to be installed and any assembly components supplied with the kit.

Parts with an alphabetic reference (Example A) are the original components fitted on the vehicle.

Any right- or left-hand indication refers to the vehicle direction of travel.

## General notes



### Warning

Carefully perform the operations on the following pages since they might negatively affect rider safety.



### Warning

Carefully perform the operations on the following pages since they might negatively affect rider safety.



### Notes

The following documents are necessary for assembling the Kit: WORKSHOP MANUAL of your bike model.



### Notes

Should it be necessary to change any kit parts, please refer to the attached spare part table.

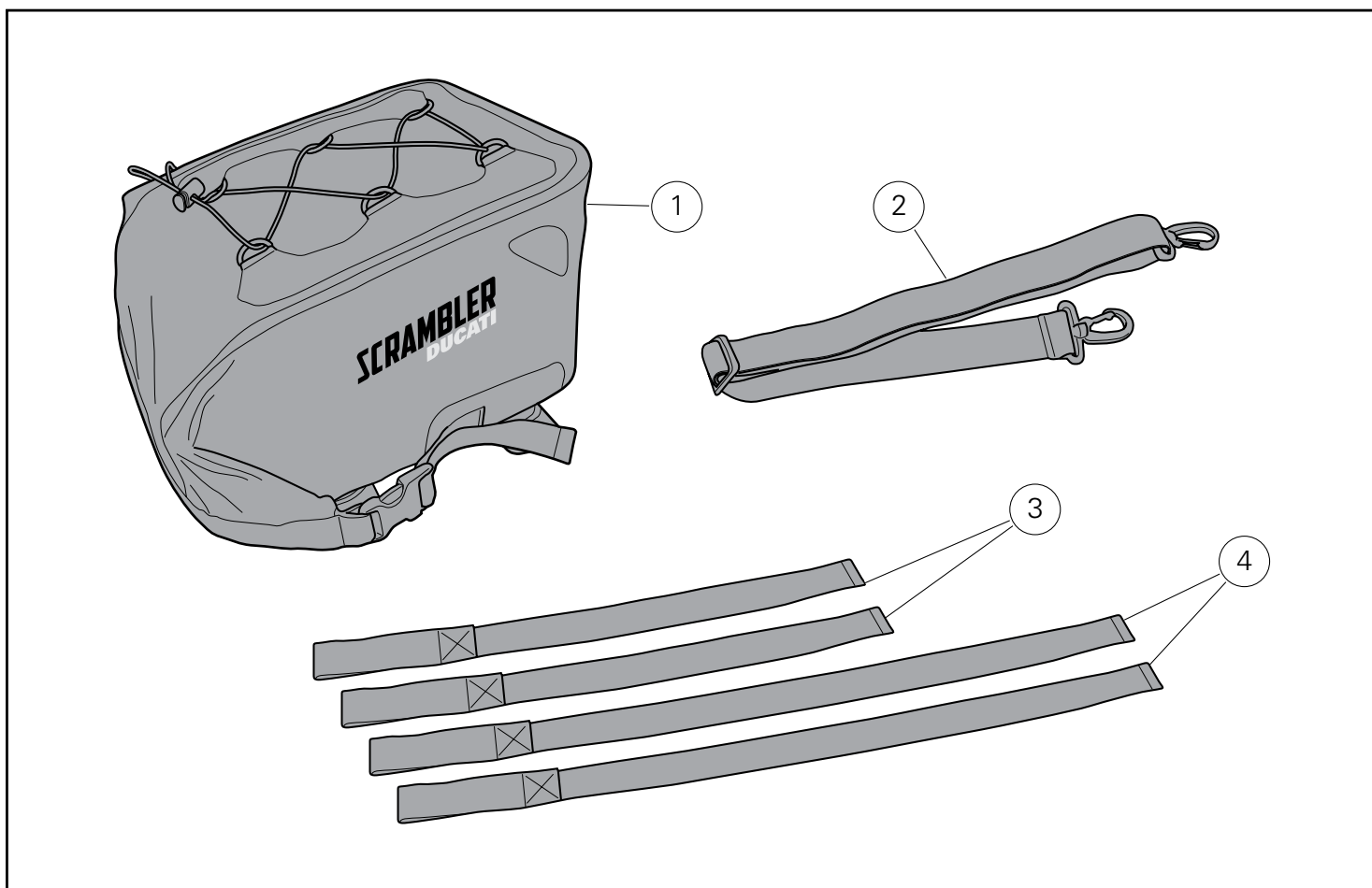

Pos.	Denominazione	Description
1	Borsa sella	Seat bag
2	Spallaccio	Shoulder strap
3	Cinghia di sicurezza cortR	Short safety belt
4	Cinghia di sicurezza lunga	Long safety belt

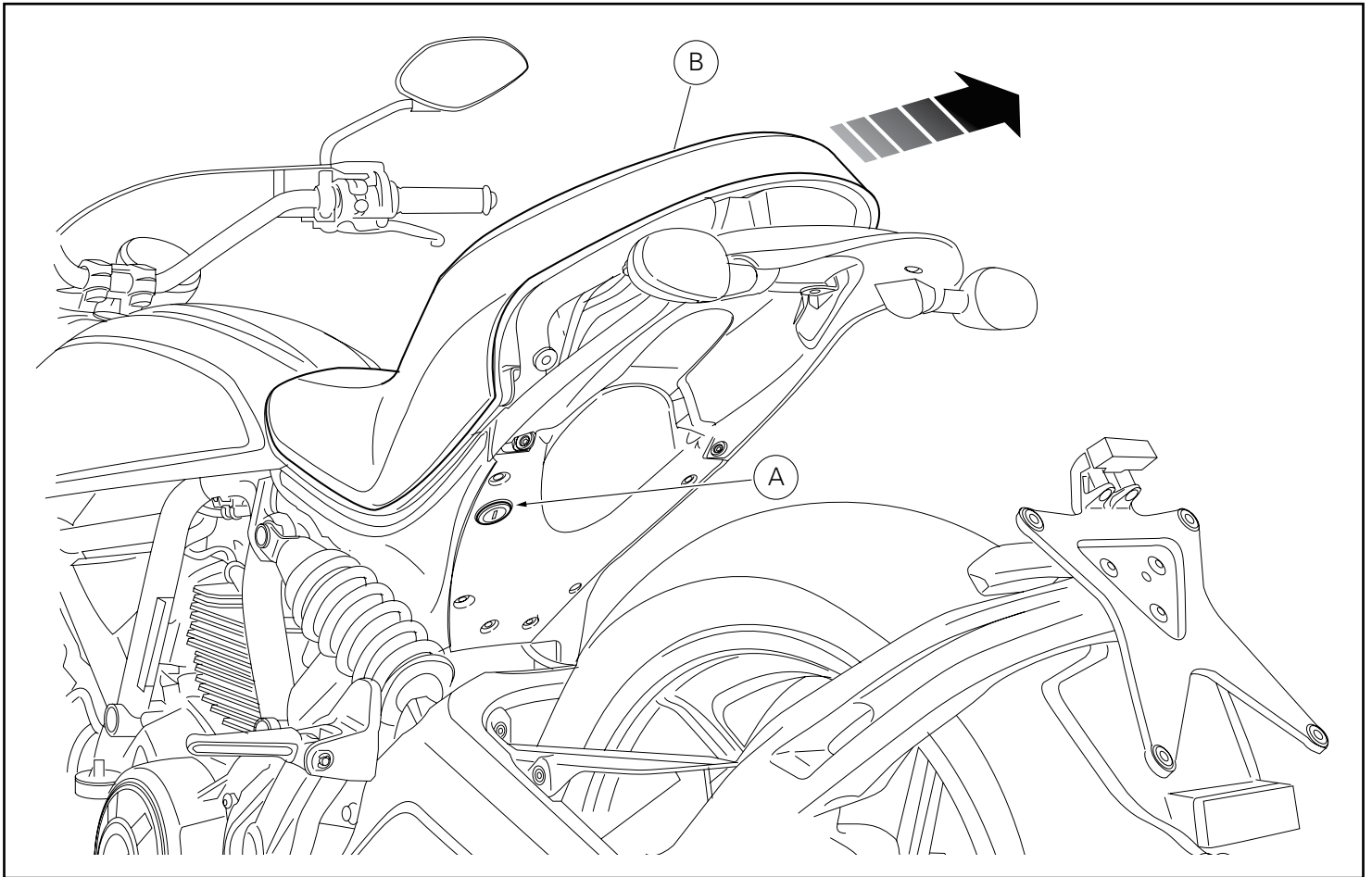

### Smontaggio componenti originali

Introdurre la chiave nella serratura (A), ruotarla in senso orario e contemporaneamente premere verso il basso in prossimità del chiavistello per agevolare lo sgancio del piolo.  
Sfilare la sella (B) dai fermi anteriori tirandola all'indietro.

### Removing the original components

Insert the key in the lock (A), turn the key clockwise and simultaneously press downward in the area of the latch to release the pin.  
Pull the seat (B) backwards to release it from the front retainers.

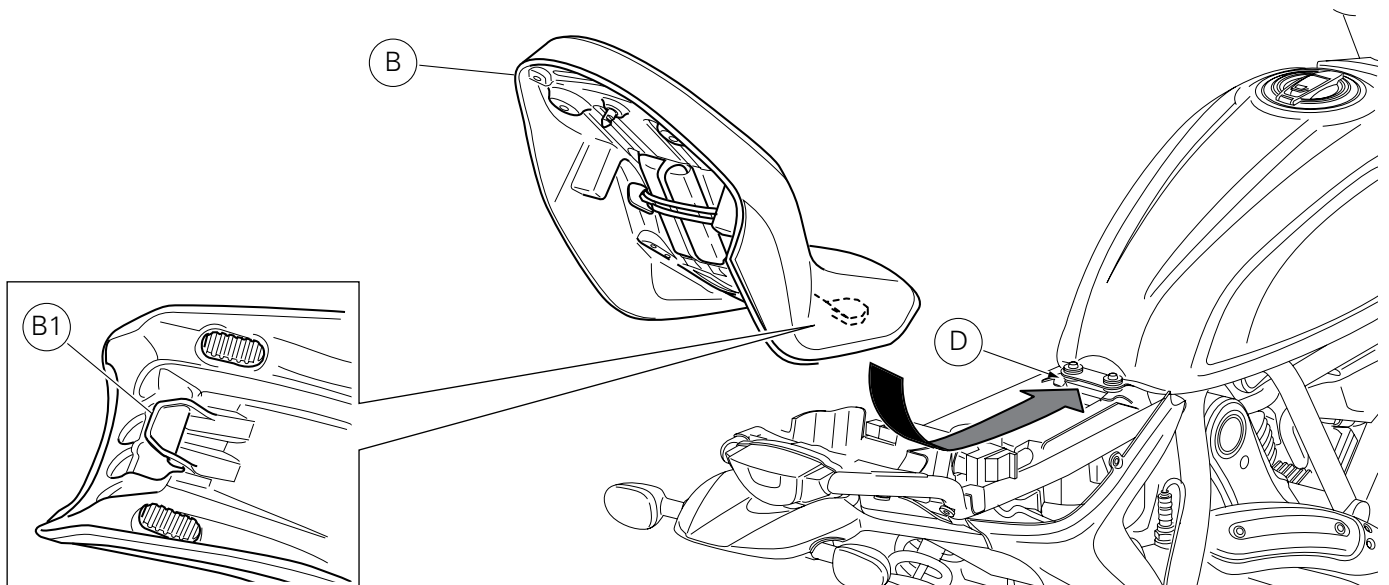
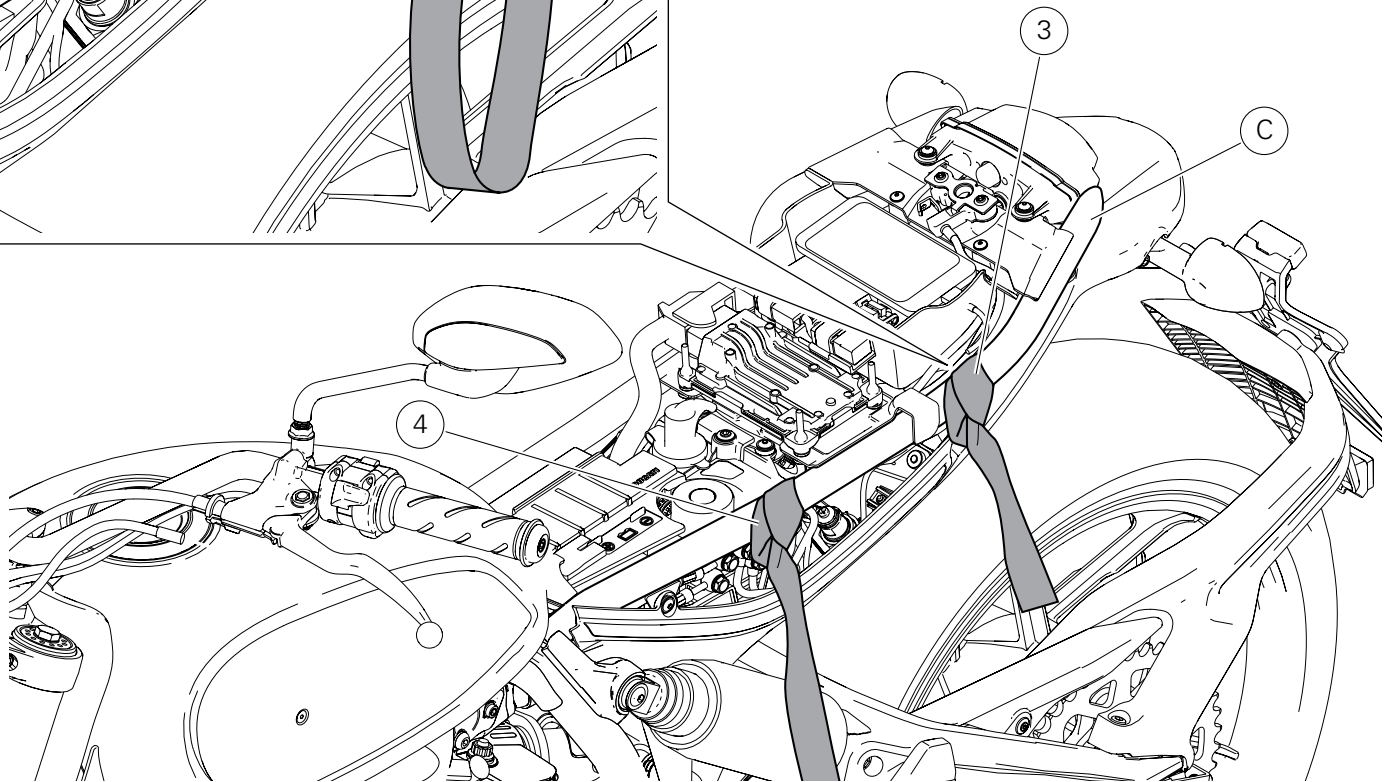
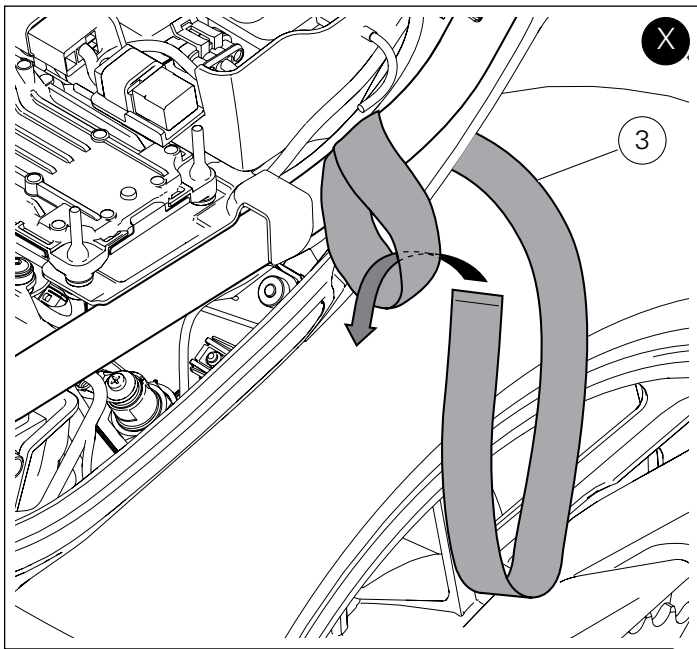

## Montaggio componenti kit



### Importante

Verificare, prima del montaggio, che tutti i componenti risultino puliti e in perfetto stato.  
Adottare tutte le precauzioni necessarie per evitare di danneggiare qualsiasi parte nella quale ci si trova ad operare.

Operando sul lato sinistro del motoveicolo, fissare la cinghia di sicurezza corta (3) nella parte posteriore del telaio (C), mentre quella lunga (4) nella parte anteriore. Per fissare le 2 cinghie di sicurezza eseguire un nodo (bocca di lupo), come indicato in figura (X).

Ripetere la stessa operazione sul lato destro del motoveicolo.

Assicurarsi che tutti gli elementi siano correttamente disposti e fissati nel vano sotto la sella.  
Inserire l'estremità anteriore (B1) del fondo sella sotto alle sede (D) del supporto telaio.  
Spingere sull'estremità posteriore della sella (B) fino ad udire lo scatto del chiavistello della serratura.  
Assicurarsi che la sella sia saldamente fissata al telaio e rimuovere la chiave dalla serratura.

## Kit installation



### Caution

Check that all components are clean and in perfect condition before installation.  
Adopt any precaution necessary to avoid damages to any part of the motorcycle you are working on.

By working on vehicle LH side, secure the short safety belt (3) to the frame rear part (C) and the long one (4) to the frame front part. Secure the 2 safety belts by making a cow hitch, as shown in figure (X).

Repeat the same procedure for motorcycle right side.

Make sure that all parts are correctly arranged and secured in the compartment under the seat.  
Slide the front end (B1) of the seat bottom underneath the seat (D) of the frame support.  
Press on seat (B) rear end until locking latch snaps.  
Make sure that the seat is firmly secured to the frame and remove the key from the lock.

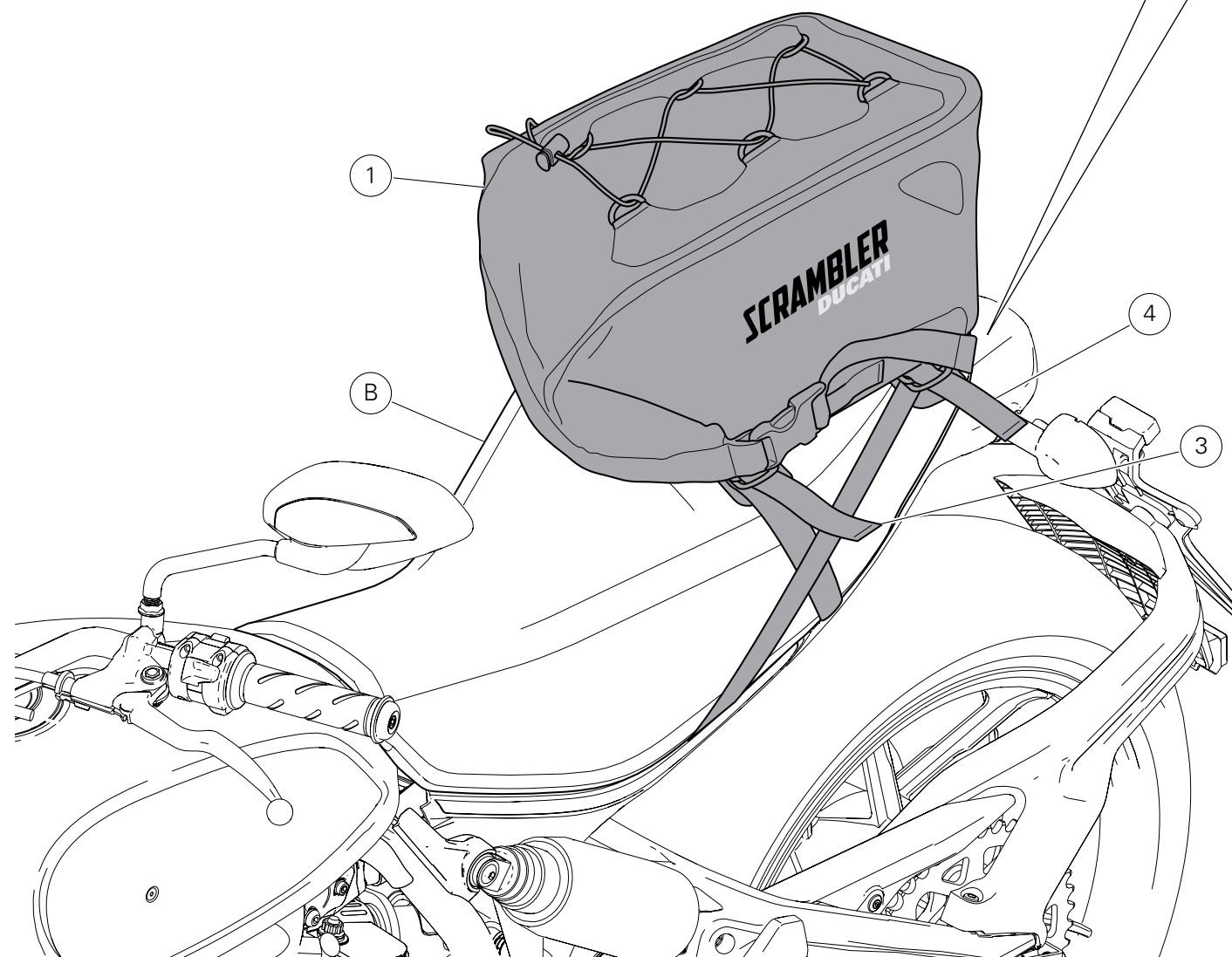
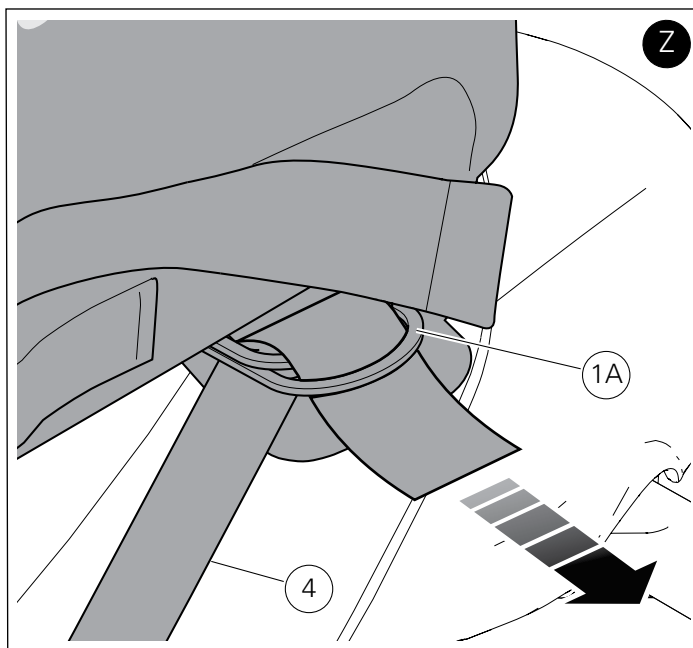
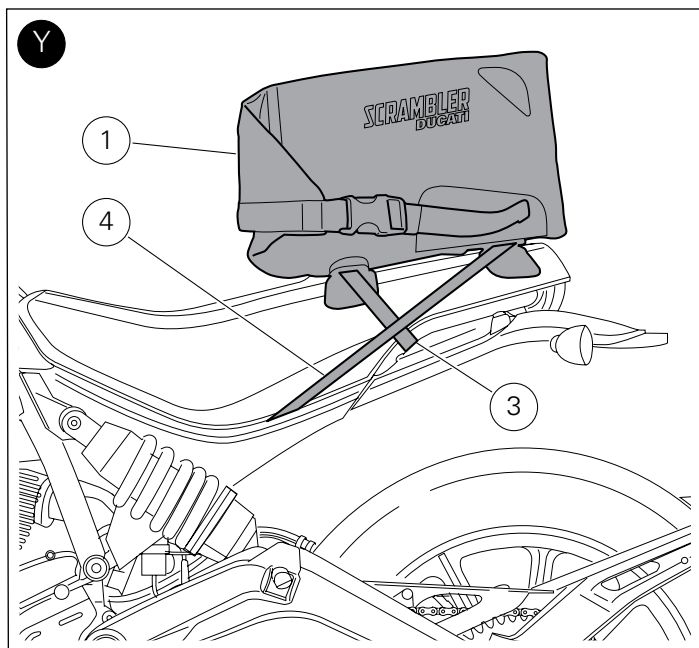

Appoggiare la borsa sella (1) sulla sella (B) nella posizione corretta. Fissare la borsa sella (1) inserendo le cinghie di sicurezza corte (3) e lunghe (4) nella apposite fibbie (1A), come indicato in figura (Z).



#### Importante

Per un corretto fissaggio della borsa sella (1) le cinghie di sicurezza corte (3) vanno inserite nelle fibbie anteriori della borsa, mentre le cinghie di sicurezza lunghe (4) vanno inserite nelle fibbie posteriori. Di conseguenza occorre che le cinghie siano incrociate fra di loro, come mostrato in figura (Y).

Tirare con forza le estremità delle n.4 cinghie di sicurezza (3) e (4) per assicurare il fissaggio della borsa alla sella.  
Raccogliere le estremità delle cinghie in maniera adeguata.

È possibile utilizzare la borsa sella (1) come zaino utilizzando l'apposito spallaccio (2).



#### Attenzione

Controllare periodicamente l'integrità delle cinghie di sicurezza.



#### Attenzione

Prima di mettersi in viaggio assicurarsi che le cinghie di sicurezza siano sempre agganciate alla borsa (1) e tensionate onde evitare il distacco della borsa stessa dal motoveicolo in fase di marcia.



#### Attenzione

È fatto obbligo di rispettare i limiti di velocità imposti dal paese in cui ci si trova a circolare e comunque è vietato oltrepassare i 130 Km/h con la borsa sella (1) montata sulla moto poiché oltre si rischia il distacco della borsa stessa.



#### Importante

La continua e prolungata esposizione agli agenti atmosferici potrebbe determinare dei minimi o sensibili cambiamenti nel colore dei tessuti/materiali.



#### Attenzione

Il peso massimo trasportabile dalla borsa sella (1) è di 5 Kg. Nel caso si ecceda il peso consigliato si rischia la rottura della borsa stessa la quale può influire negativamente sulla sicurezza del pilota.

Quando si effettua il lavaggio della moto è necessario rimuovere la borsa sella (1).

### Verifiche

Verificare che la borsa sella (1) sia fissata saldamente al telaio (C).

Set seat bag (1) on seat (B) in the proper position.

Fix seat bag (1) by inserting the short (3) and long (4) safety belts inside the special buckles (1A), as shown in the figure (Z).



#### Caution

For a correct fastening of seat bag (1) the short (3) and long (4) safety belts must be respectively inserted inside the front and rear buckles of the bag.

As a result, belts must be crossed to each other as shown in the figure (Y).

Pull hard the ends of the 4 safety belts (3) and (4) to ensure the fastening of the bag to the seat.

Gather the belts ends in a proper way.

It is possible to use the seat bag (1) as a rucksack by using the special shoulder strap (2).



#### Warning

Periodically check the integrity of the safety belts.



#### Warning

Before riding, make sure safety belts are always fastened to bag (1) and tensioned so as to prevent the bag from releasing from motorcycle while riding.



#### Warning

You are required to strictly comply with the speed limits of the country where you are riding; in any case, never exceed 130 Km/h when the seat bag (1) is installed to the bike or the bag could detach.



#### Caution

Continuous and prolonged exposure to weather may create minor discoloration in the fabrics/materials.



#### Warning

Maximum load that can be carried by the seat bag (1) is 5 Kg. Do not exceed this limit or the bag might break thus jeopardizing rider safety.

When washing the motorcycle, always remove the seat bag (1).

### Checks

Check that seat bag (1) is securely attached to the frame (C).





## Kit sac de selle étanche OUTDOOR / Kit wasserdichte Sitzbanktasche OUTDOOR



## Symboles

Pour faciliter la consultation de ce manuel, des symboles signalent des situations exigeant le maximum d'attention, des conseils pratiques ou de simples informations. Lire attentivement la signification de ces symboles car ils renvoient à des concepts techniques ou des consignes de sécurité de la plus grande importance. Ils doivent être considérés comme de véritables « aide-mémoire ». Toujours consulter cette page en cas de doute concernant leur signification.



## Attention

La non-observance des instructions reportées ci-dessous peut créer une situation dangereuse et provoquer de graves lésions personnelles voire la mort.



## Important

Indique la possibilité d'endommager le véhicule et/ou ses composants si les instructions reportées ci-dessous ne sont pas suivies.



## Remarques

Fournit des informations utiles sur l'opération en cours.

## Références

Les pièces surlignées en gris et la référence numérique (Ex. ①) représentent l'accessoire à installer et les composants de montage éventuels fournis en kit.

Les pièces avec référence alphabétique (Ex. Ⓐ) représentent les composants d'origine présents sur le motorcycle.

Toutes les indications droite ou gauche se réfèrent au sens de marche la moto.

## Avertissements généraux



## Attention

Les opérations indiquées dans les pages suivantes, au cas où elles ne seraient pas effectuées selon les règles de l'art pourraient compromettre la sécurité du pilote.



## Attention

Les opérations indiquées dans les pages suivantes, au cas où elles ne seraient pas effectuées selon les règles de l'art pourraient compromettre la sécurité du pilote.



## Remarques

La documentation nécessaire pour effectuer la pose du Kit est le : MANUEL D'ATELIER, relatif au modèle de moto en votre possession.



## Remarques

Au cas où il serait nécessaire d'effectuer le remplacement d'un composant du kit, il faudra consulter la planche relative aux pièces détachées ci-jointe.

## Symbole

Zum schnellen und übersichtlichen Lesen werden Symbole verwendet, die außerordentlich wichtige Situationen, praktische Ratschläge oder auch nur einfache Informationen hervorheben. Der Bedeutung dieser Symbole ist besondere Aufmerksamkeit zu schenken, da sich hierdurch das ständige Wiederholen von technischen Konzepten oder Sicherheitshinweisen erübrigt. Sie stellen daher regelrechte „Merker“ dar. Diese Seite ist immer dann zur Hand zu nehmen, wenn Zweifel über die Bedeutung eines Symbols bestehen sollten.



## Achtung

Eine Nichtbeachtung der hier wiedergegebenen Anweisungen kann Gefahrensituationen schaffen und zu schweren Verletzungen und auch zum Tod führen.



## Wichtig

Weist darauf hin, dass bei Nichteinhaltung der hier wiedergegebenen Anweisungen die Möglichkeit für Schäden am Fahrzeug und/oder seiner Komponenten besteht.



## Hinweis

Übermittelt nützliche Informationen zum betreffenden Arbeitseingriff.

## Bezugsangaben

Die grau gekennzeichneten Bestandteile mit numerischem Bezug (Bsp. ①) geben das zu installierende Bestandteil und die eventuellen, im Kit enthaltenen Montagekomponenten wieder.

Die Bestandteile mit alphabetischem Bezug (Bsp. Ⓐ) geben die Original-Bestandteile wieder, die am Motorrad verbaut wurden.

Alle Angaben wie „rechts“ oder „links“ beziehen sich auf die Fahrtrichtung des Motorrads.

## Allgemeine Warnhinweise



## Achtung

Werden die auf den folgenden Seiten beschriebenen Arbeitsmaßnahmen nicht fachgerecht ausgeführt, kann sich dies auf die Sicherheit des Fahrers auswirken.



## Achtung

Werden die auf den folgenden Seiten beschriebenen Arbeitsmaßnahmen nicht fachgerecht ausgeführt, kann sich dies auf die Sicherheit des Fahrers auswirken.



## Hinweis

Für die Montage des Kits sind folgende Unterlagen erforderlich: WERKSTATTHANDBUCH, des sich in Ihrem Besitz befindlichen Motorrads.



## Hinweis

Sollte sich der Austausch eines Bestandteils des Kits als erforderlich erweisen, ist dazu Bezug auf die beiliegende Ersatzteilliste zu nehmen.

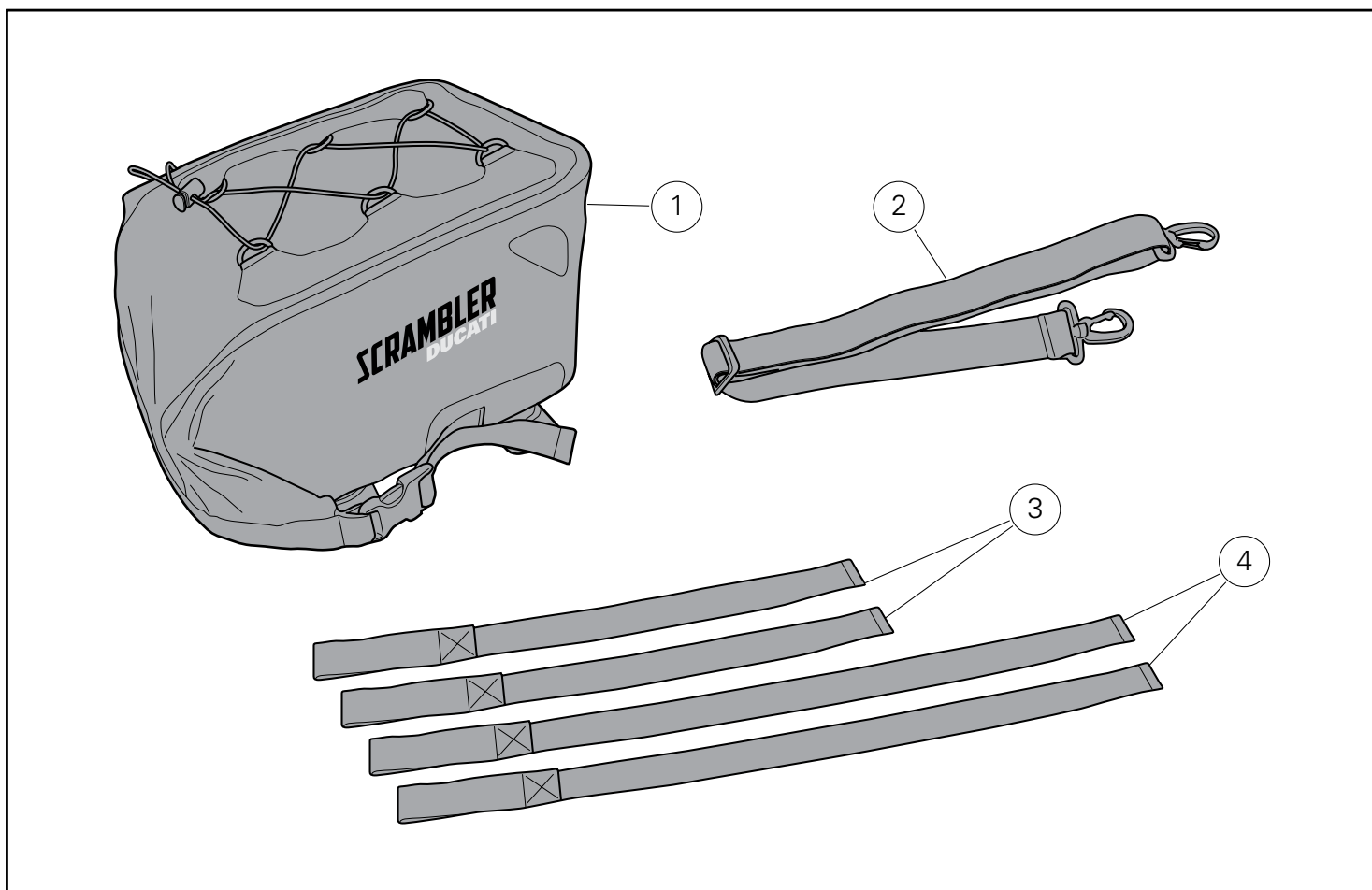

Pos.	Designation	Bezeichnung
1	Sac de selle	Sitzbanktasche
2	Épaulière	Schultergurt
3	Courroie de sécurité courte	Kurzen Sicherheitsriemen
4	Courroie de sécurité longue	Langen Sicherheitsriemen

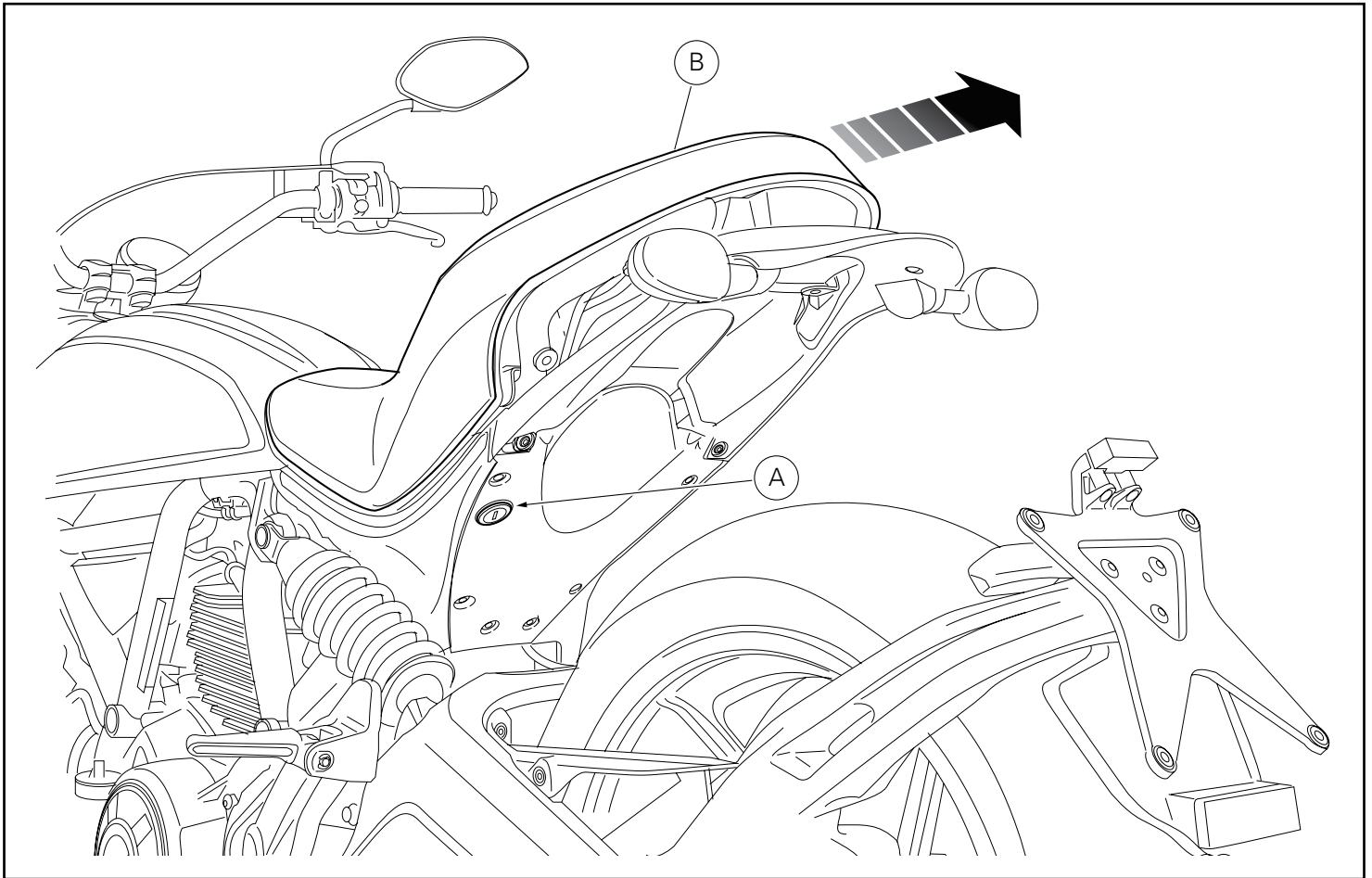

### Dépose composants d'origine

Insérer la clé dans la serrure (A), la tourner dans le sens des aiguilles d'une montre et, en même temps, exercer une pression vers le bas à proximité du verrou pour faciliter le décrochage de la vis sans tête.  
Sortir la selle (B) des arrêts avant en la tirant vers l'arrière.

### Ausbau der Original-Bestandteile

Den Schlüssel in das Schloss (A) einstecken, im Uhrzeigersinn drehen und dabei gleichzeitig am Riegel nach unten drücken, um das Lösen des Verriegelungsstifts zu erleichtern.  
Die Sitzbank (B) durch Ziehen nach hinten von den vorderen Halterungen entfernen.

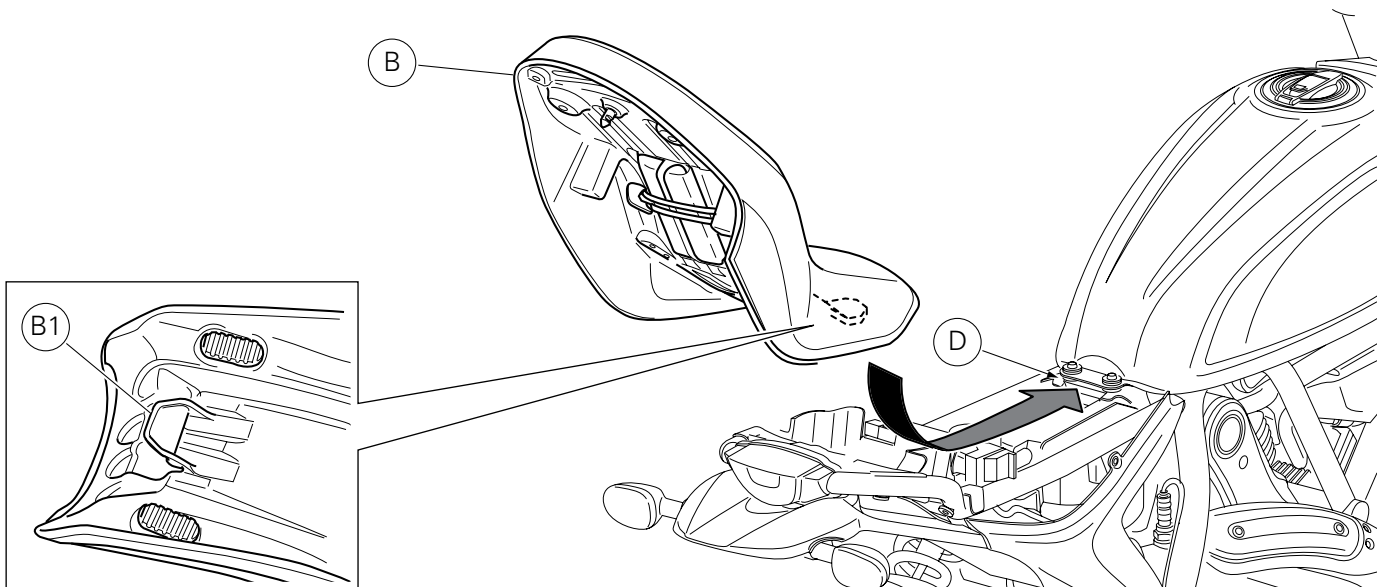
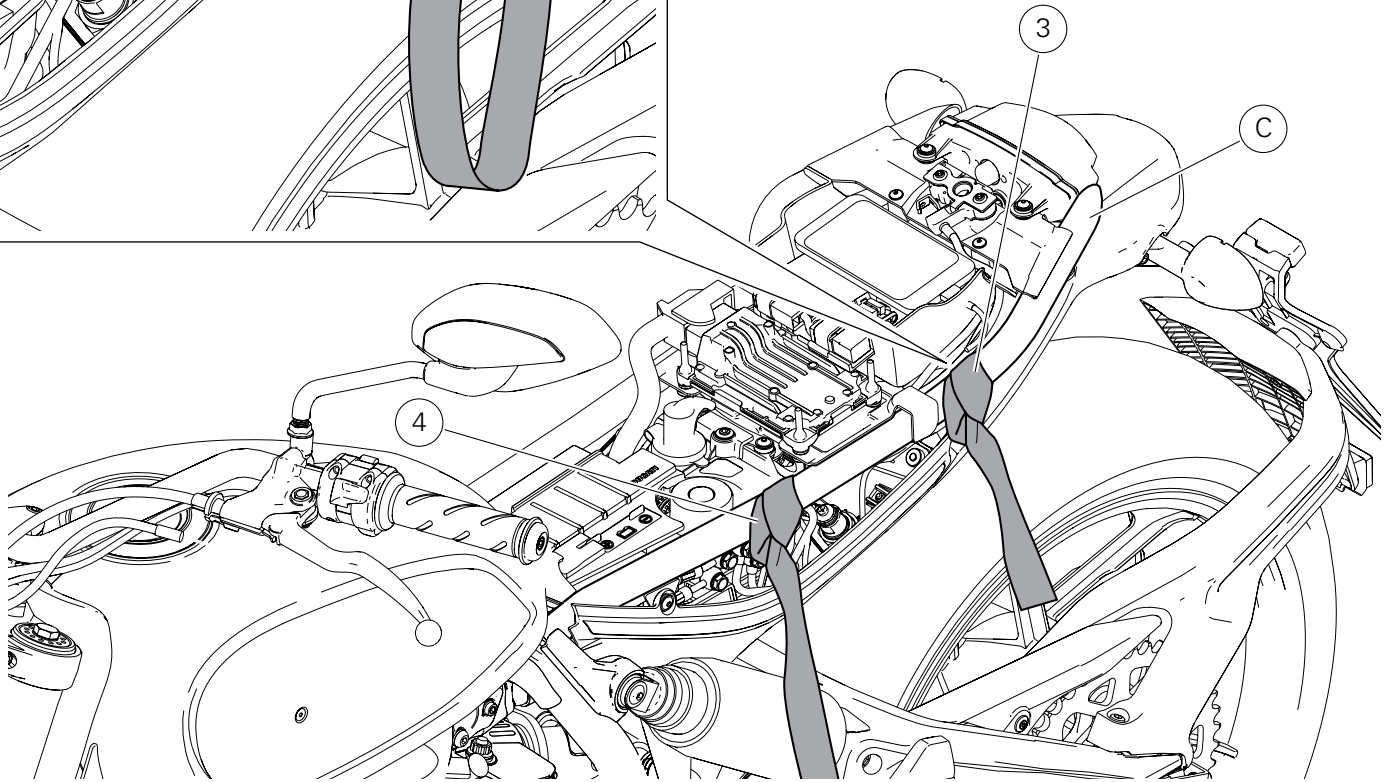
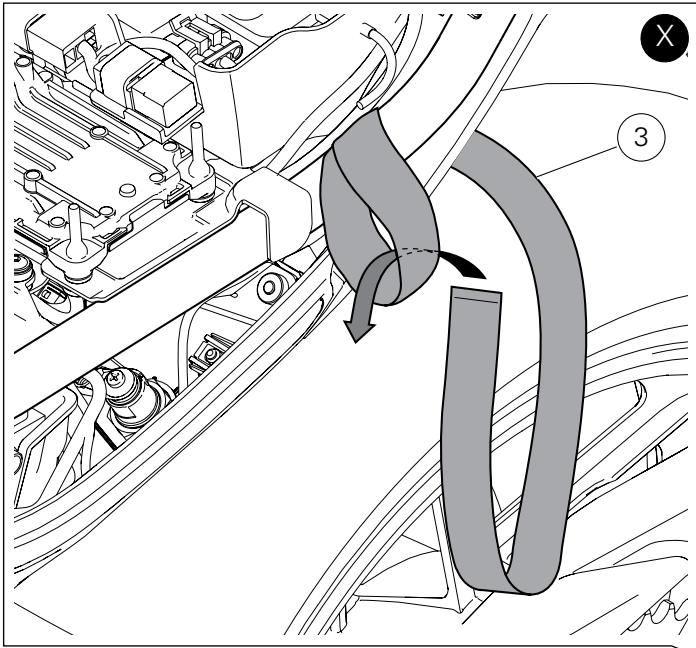

## Pose composants kit



### Important

Vérifier, avant la pose, que tous les composants sont propres et en parfait état.

Adopter toutes les précautions nécessaires pour éviter d'endommager la surface externe des composants où on opère.

En agissant du côté gauche du motorcycle, fixer la courroie de sécurité courte (3) à la partie arrière du cadre (C) et la courroie longue (4) à la partie avant. Pour fixer les 2 courroies de sécurité il est nécessaire de faire un nœud (gueule de loup), comme illustré dans la figure (X).

Répéter la même opération sur le côté droit du motorcycle.

Vérifier que tous les éléments soient correctement placés et fixés dans le compartiment dessous de selle.

Insérer l'extrémité avant (B1) du fond de selle au-dessous du logement (D) du support du cadre.

Pousser sur l'extrémité arrière de la selle (B) jusqu'à ce que l'on entende le déclic du verrou de la serrure.

Vérifier que la selle soit solidement fixée au cadre et déposer la clé de la serrure.

## Montage der Komponenten des Kits



### Wichtig

Vor der Montage überprüfen, dass sich alle Komponenten im sauberen und perfekten Zustand befinden.

Alle erforderlichen Vorsichtsmaßnahmen treffen, um eine Beschädigung der Oberflächen der Komponenten, die vom Eingriff betroffen sind, zu vermeiden.

An der linken Seite des Motorrads den kurzen Sicherheitsriemen (3) am hinteren Teil und den langen (4) am vorderen Teil des Rahmens (C) befestigen. Zur Befestigung der 2 Sicherheitsriemen, diese wie in der Abbildung (X) dargestellt verknoten (Slipknoten). Den gleichen Arbeitsschritt an der rechten Seite des Motorrads wiederholen.

Sicherstellen, dass alle Elemente korrekt angeordnet und im Sitzbankfach befestigt sind.

Das vordere Endstück (B1) des Sitzbankbodens unter den Sitz (D) des Rahmenträgers einfügen.

Auf den hinteren Bereich der Sitzbank (B) drücken, bis das Einrasten der Schlossverriegelung zu hören ist.

Sicherstellen, dass die Sitzbank fest am Rahmen befestigt ist, dann den Schlüssel aus dem Schloss ziehen.

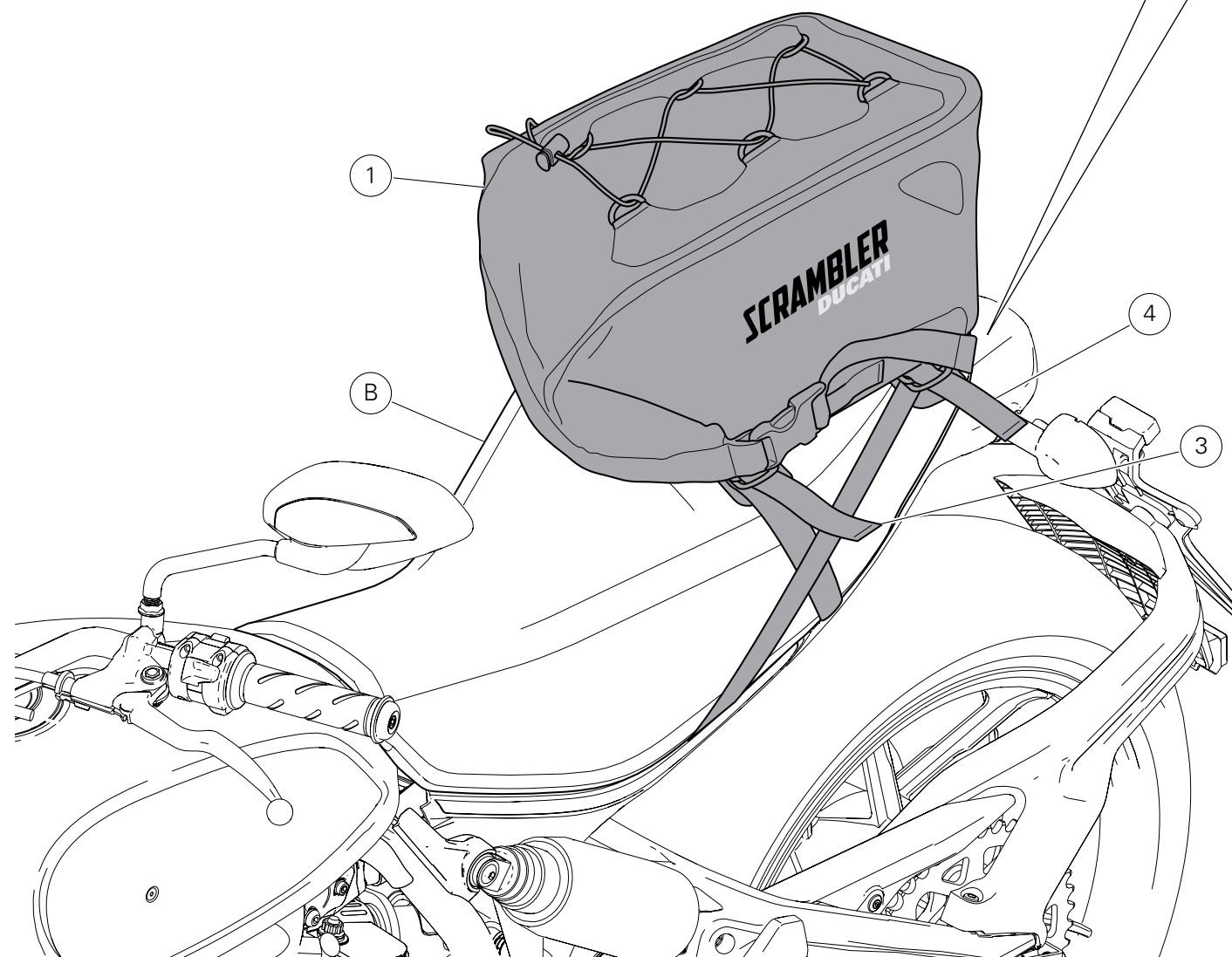
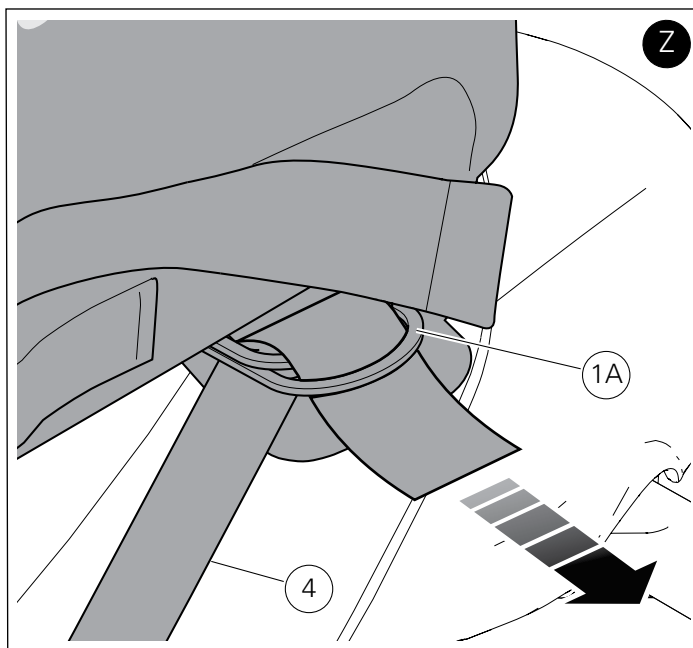
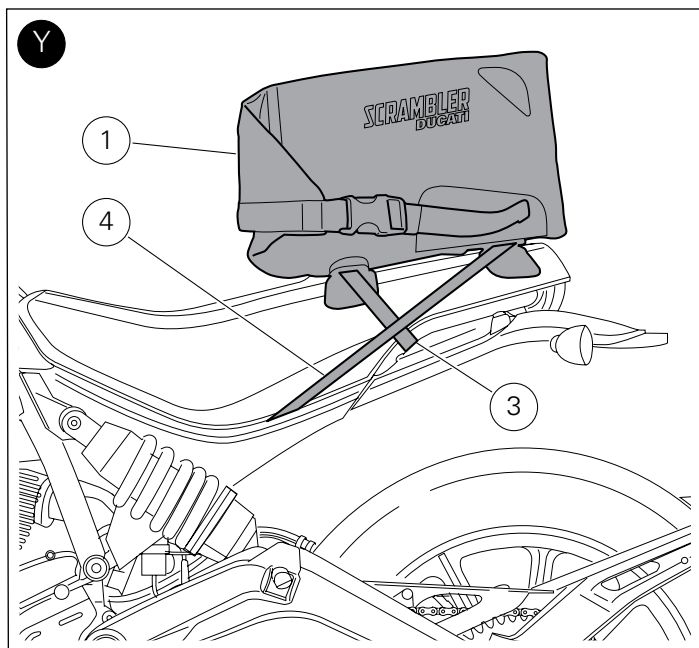

Appuyer le sac de selle (1) sur la selle (B) dans la position correcte. Fixer le sac de selle (1) en insérant les courroies de sécurité courtes (3) et longues (4) dans les boucles (1A) prévues à cet effet, comme indiqué dans la figure (Z).



#### Important

Pour fixer correctement le sac de selle (1), il faut que les courroies de sécurité (3) soient insérées dans les boucles avant du sac, alors que les courroies de sécurité longues (4) doivent être insérées dans les boucles arrière.

Par conséquent, il faut que les courroies soient croisées entre elles, comme la figure le montre (Y).

Tirer avec force les extrémités des 4 courroies de sécurité (3) et (4) pour assurer la fixation du sac à la selle.

Rassembler les extrémités des courroies de manière adéquate.

Il est possible d'utiliser le sac de selle (1) comme sac à dos, en utilisant l'épaulière (2) prévue à cet effet.



#### Attention

Contrôler périodiquement l'intégrité des courroies de sécurité.



#### Attention

Avant de se mettre en route, s'assurer que les courroies de sécurité (3) soient toujours fixées à la sacoche (1) et tendues afin d'éviter que la sacoche se détache du motorcycle pendant la marche.



#### Attention

Il faut absolument respecter les limitations de vitesse en vigueur dans le pays de circulation ; il est en tout cas interdit de dépasser les 130 Km/h le sac (1) monté sur la moto car au-delà de cette vitesse il y a le risque de détachement du sac de la selle.



#### Important

Une exposition continue et prolongée aux intempéries peut créer une décoloration mineure des tissus/matières.



#### Attention

Le poids transportable dans le sac (1) ne peut pas excéder 5 Kg. Au cas où le poids excéderait celui conseillé il y a le risque de rupture du sac, et donc la sécurité du pilote peut être compromise.

Lorsqu'on effectue le lavage du motorcycle, il est nécessaire de déposer la sacoche de la selle (1).

## Vérifications

Vérifier que la sacoche de selle (1) soit solidement fixée au cadre (C).

Die Sitzbanktasche (1) in korrekter Position auf der Sitzbank (B) auflegen.

Die Sitzbanktasche (1) schließlich befestigen, dazu die kurzen (3) und langen Sicherungsriemen (4) in die entsprechenden Schnallen (1A) einführen, siehe Abbildung (Z).



#### Wichtig

Zur korrekten Befestigung der Sitzbanktasche (1) müssen die kurzen Sicherheitsriemen (3) in die vorderen Schnallen der Tasche eingeführt werden, während die langen Sicherheitsriemen (4) in die hinteren Schnallen eingefügt werden müssen.

Demzufolge müssen sich die Riemen gemäß Abbildung (Y) überkreuzen.

Kräftig an den Enden der 4 Sicherheitsriemen (3) und (4) ziehen, um die Befestigung der Sitzbanktasche zu gewährleisten.

Die Riemenenden in angemessener Weise zusammenfassen.

Die Sitzbanktasche (1) kann mit dem entsprechenden Schultergurt (2) auch als Rucksack verwendet werden.



#### Achtung

Regelmäßig kontrollieren, dass die Sicherheitsriemen keine Schäden aufweisen.



#### Achtung

Vor dem Losfahren sicherstellen, dass die Sicherheitsriemen stets an der Tasche (1) eingehakt und gespannt sind, um beim Fahren ein Lösen der Tasche zu vermeiden.



#### Achtung

Bei am Motorrad montierter Tasche müssen die von dem Land, in dem man das Motorrad fährt vorgegebenen Geschwindigkeitsbegrenzungen eingehalten werden, dabei darf jedoch die Geschwindigkeit von 130 km/h nie überschritten (1) werden, da sich die Tasche sonst von der Sitzbank lösen könnte.



#### Wichtig

Die ständige und dauernde Aussetzung der Wetterlage könnte minimale Färbänderungen der Stoffe/Materialien verursachen.



#### Achtung

Das maximal in der Tasche (1) transportierbare Gewicht beträgt 5 kg. Sollte das empfohlene Gewicht überschritten werden, besteht die Gefahr, dass die Tasche reißt, was sich negativ auf die Sicherheit des Fahrers auswirken kann.

Vor der Wäsche des Motorrads muss die Hecktasche (1) abgenommen werden.

## Überprüfungen

Überprüfen, dass die Hecktasche (1) fest am Rahmen (C) befestigt ist.





## Conjunto bolsa para assento hermética OUTDOOR / Sealed seat bag kit - OUTDOOR



## Símbolos

Para uma leitura rápida e racional, foram utilizados símbolos que evidenciam situações de máxima atenção, conselhos práticos ou simples informações. Preste muita atenção ao significado dos símbolos, pois a sua função é a de evitar a repetição de conceitos técnicos ou de avisos de segurança. Portanto, os símbolos devem ser considerados como verdadeiros "lembretes". Consulte esta página sempre que tiver dúvidas acerca do seu significado.



## Atenção

O não cumprimento das instruções mostradas pode criar uma situação de perigo e causar graves lesões pessoais e até mesmo a morte.



## Importante

Indica a possibilidade de causar danos ao veículo e/ou aos seus componentes se as instruções mostradas não forem executadas.



## Notas

Fornisce utili informazioni sull'operazione in corso.

## Referências

Os detalhes evidenciados em cinza e com referência numérica (Ex. ①) representam o acessório a ser instalado e os eventuais componentes de montagem fornecidos como kit.

Os detalhes com referência alfabética (Ex. A) representam os componentes originais presentes na moto.

Todas as indicações direita ou esquerda, referem-se ao sentido de marcha da moto.

## Advertências gerais



## Atenção

As operações mostradas nas páginas a seguir, se não forem executadas com boa técnica, podem prejudicar a segurança do condutor.



## Atenção

As operações mostradas nas páginas a seguir, se não forem executadas com boa técnica, podem prejudicar a segurança do condutor.



## Notas

Documentação necessária para executar a montagem do Conjunto: MANUAL DE OFICINA, relativo ao modelo de moto em sua posse.



## Notas

Caso seja necessária a substituição de um componente do conjunto, consulte o quadro de peças de reposição em anexo.

## Symbols

To allow quick and easy consultation, this manual uses graphic symbols to highlight situations in which maximum care is required, as well as practical advice or information.

Pay attention to the meaning of the symbols since they serve to avoid repeating technical concepts or safety warnings throughout the text. The symbols should therefore be seen as real reminders. Please refer to this page whenever in doubt as to their meaning.



## Warning

Failure to follow these instructions might give rise to a dangerous situation and provoke severe personal injuries or even death.



## Caution

Failure to follow these instructions might cause damages to the vehicle and/or its components.



## Notes

Useful information on the procedure being described.

## References

Parts highlighted in grey and with a numeric reference (Example ①) are the accessory to be installed and any assembly components supplied with the kit.

Parts with an alphabetic reference (Example A) are the original components fitted on the vehicle.

Any right- or left-hand indication refers to the vehicle direction of travel.

## General notes



## Warning

Carefully perform the operations on the following pages since they might negatively affect rider safety.



## Warning

Carefully perform the operations on the following pages since they might negatively affect rider safety.



## Notes

The following documents are necessary for assembling the Kit: WORKSHOP MANUAL of your bike model.



## Notes

Should it be necessary to change any kit parts, please refer to the attached spare part table.

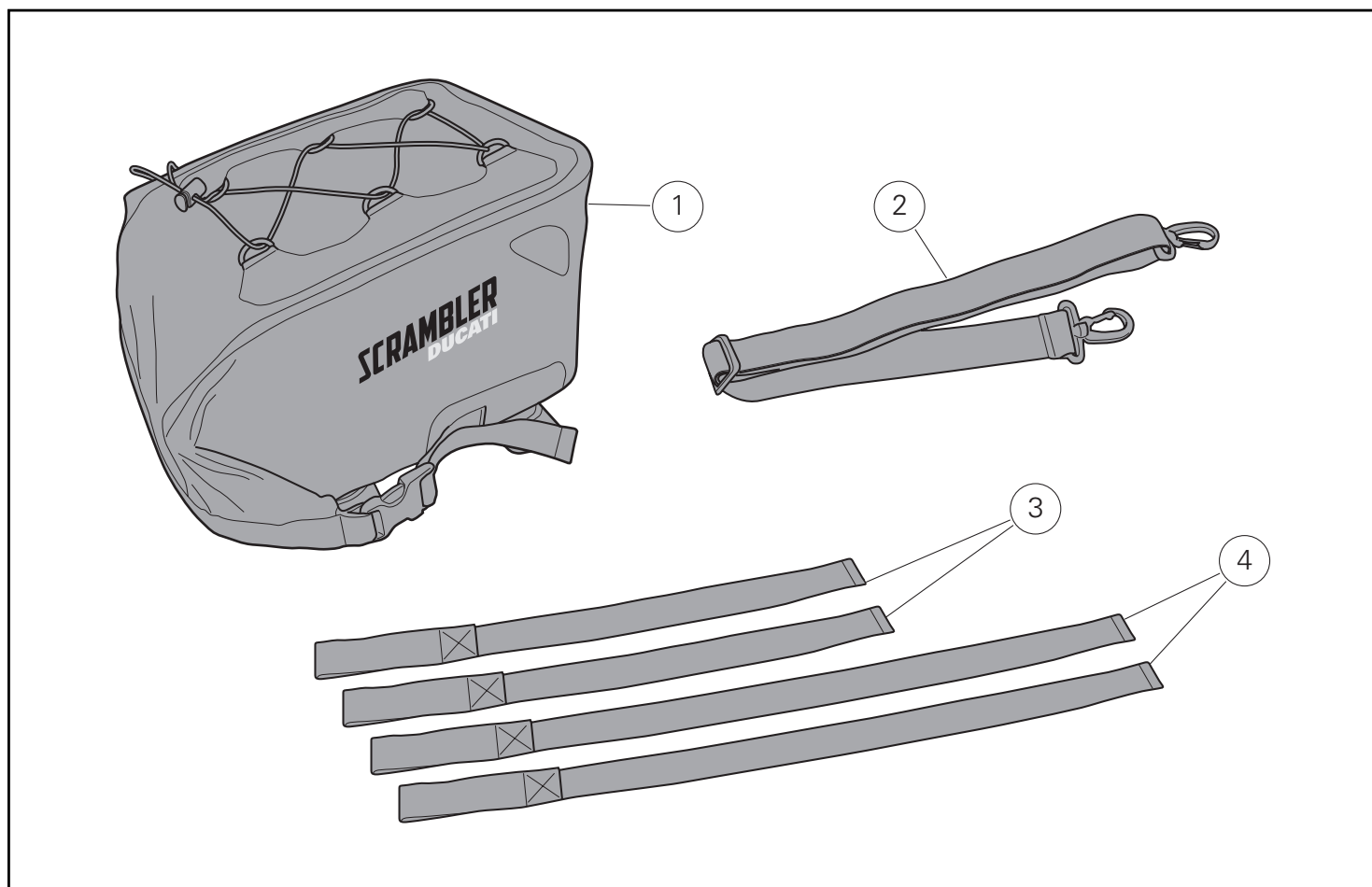

Pos.	Descrição	Description
1	Bolsa para assento	Seat bag
2	Bandoleira	Shoulder strap
3	Tira de segurança curto	Short safety belt
4	Tira de segurança comprido	Long safety belt

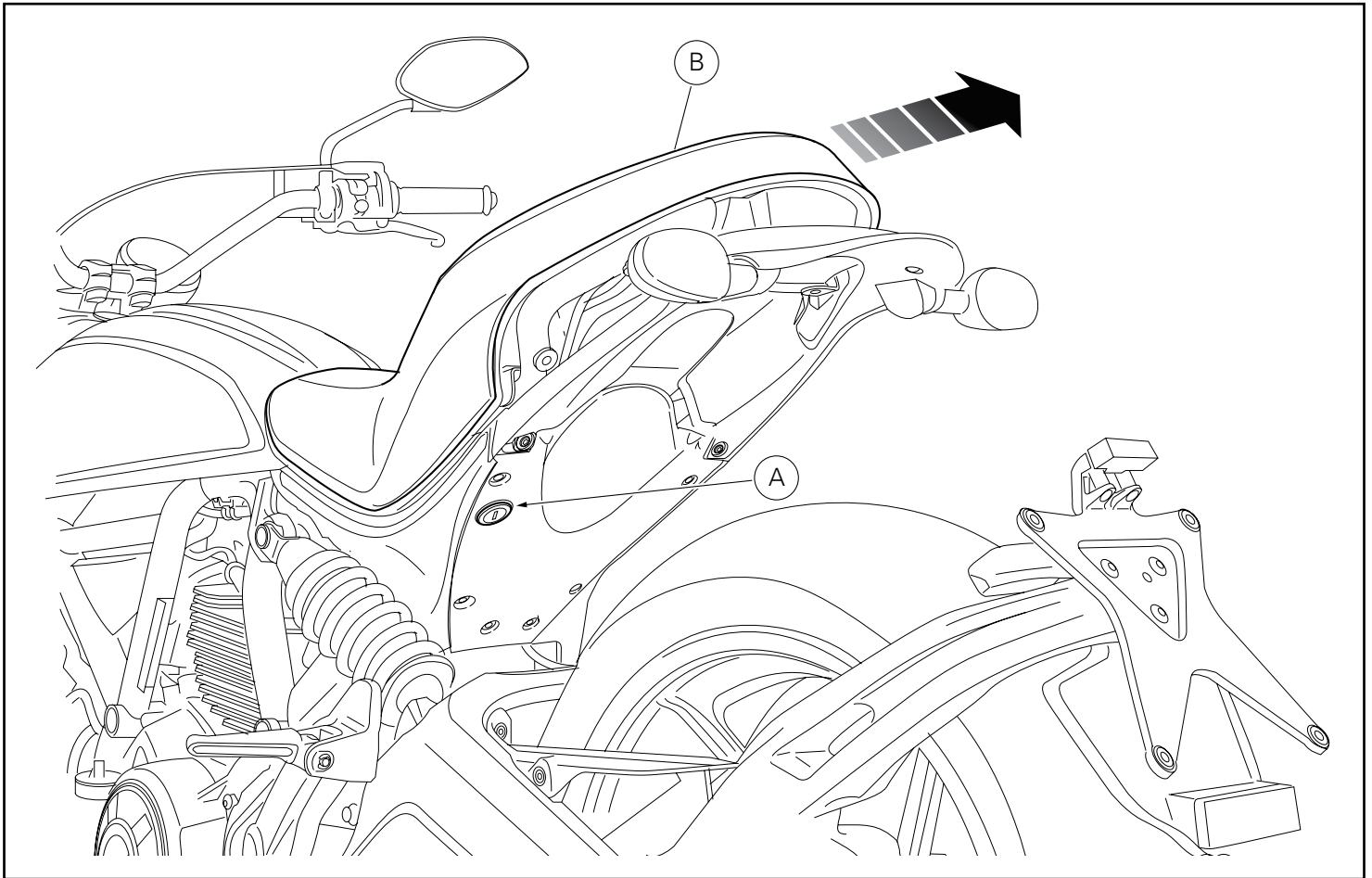

### Desmontagem dos componentes originais

Introduza a chave na fechadura (A), gire-a no sentido horário e simultaneamente pressione para baixo perto do ferrolho para facilitar o desengate do pino.  
Retire o assento (B) dos retentores dianteiros, puxando-o para trás.

### Removing the original components

Insert the key in the lock (A), turn the key clockwise and simultaneously press downward in the area of the latch to release the pin.  
Pull the seat (B) backwards to release it from the front retainers.

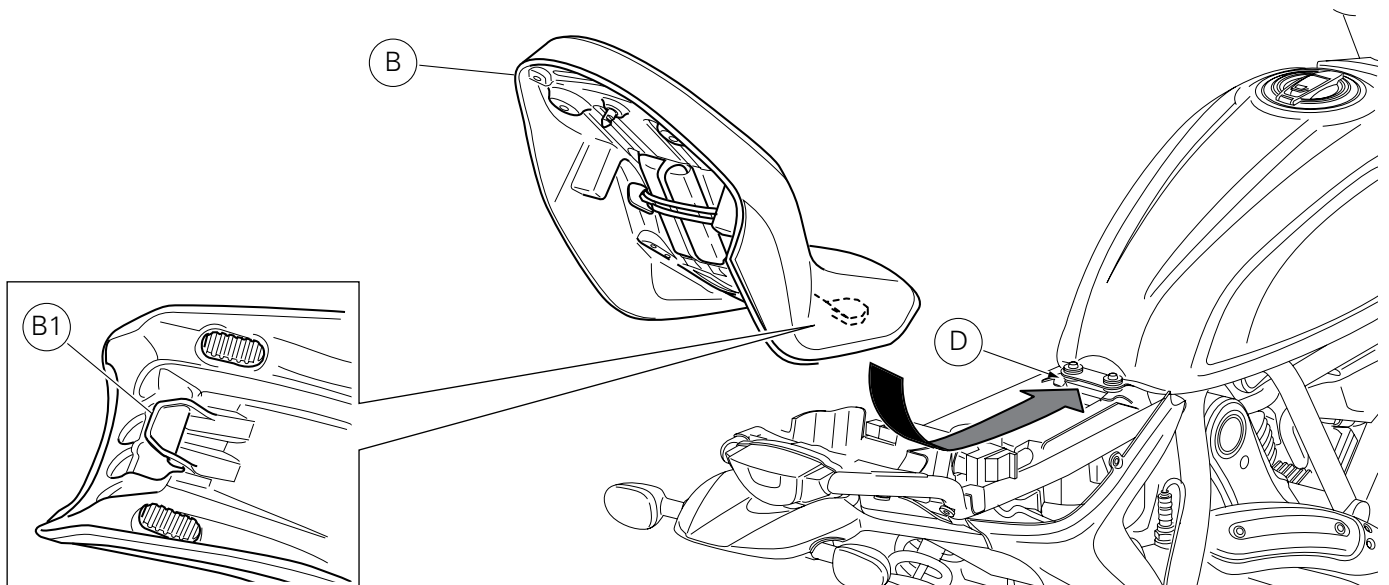
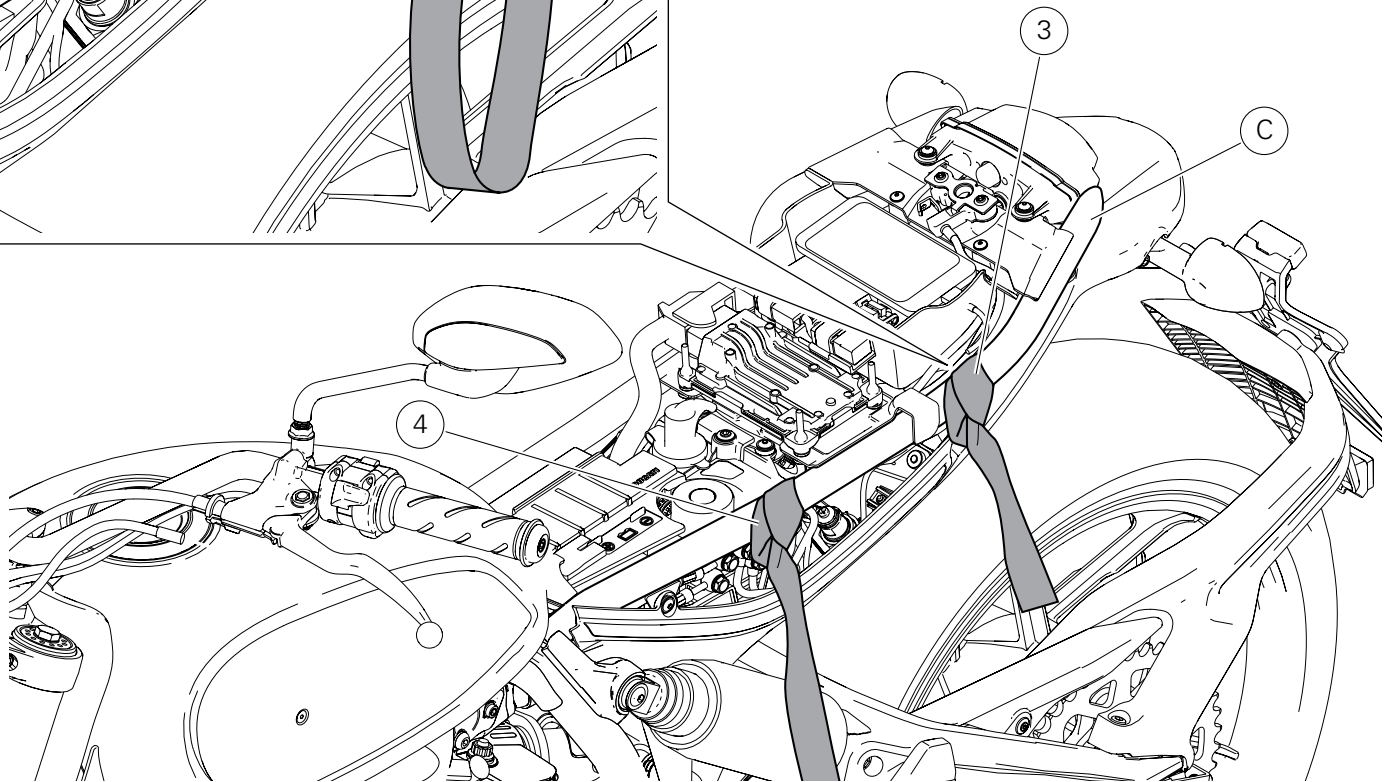
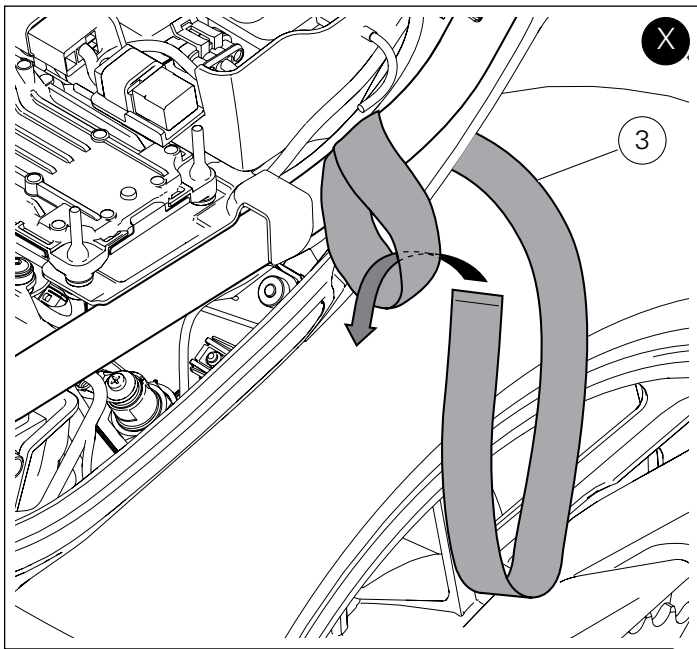

## Montagem dos componentes



### Importante

Verifique, antes da montagem, se todos os componentes estão limpos e em perfeito estado. Adote todas as precauções necessárias para evitar danificar qualquer peça com a qual deve trabalhar.

Atuando no lado esquerdo da moto, fixe o cinto de segurança curto (3) na parte posterior do chassi (C) e o comprido (4) na parte anterior. Para fixar os 2 cintos de segurança execute um nó (boca de lobo), conforme indicado na figura (X).

Repita a mesma operação no lado direito da moto.

Certifique-se de que todos os elementos estejam corretamente dispostos e fixados no compartimento debaixo do assento.

Insira a extremidade dianteira (B1) do fundo do assento debaixo da sede (D) do suporte do chassi.

Empurre na extremidade traseira do assento (B) até ouvir o disparo do ferrolho da fechadura.

Certifique-se de que o assento esteja fixado firmemente ao chassi e remova a chave da fechadura.

## Kit installation



### Caution

Check that all components are clean and in perfect condition before installation.

Adopt any precaution necessary to avoid damages to any part of the motorcycle you are working on.

By working on vehicle LH side, secure the short safety belt (3) to the frame rear part (C) and the long one (4) to the frame front part. Secure the 2 safety belts by making a cow hitch, as shown in figure (X).

Repeat the same procedure for motorcycle right side.

Make sure that all parts are correctly arranged and secured in the compartment under the seat.

Slide the front end (B1) of the seat bottom underneath the seat (D) of the frame support.

Press on seat (B) rear end until locking latch snaps.

Make sure that the seat is firmly secured to the frame and remove the key from the lock.

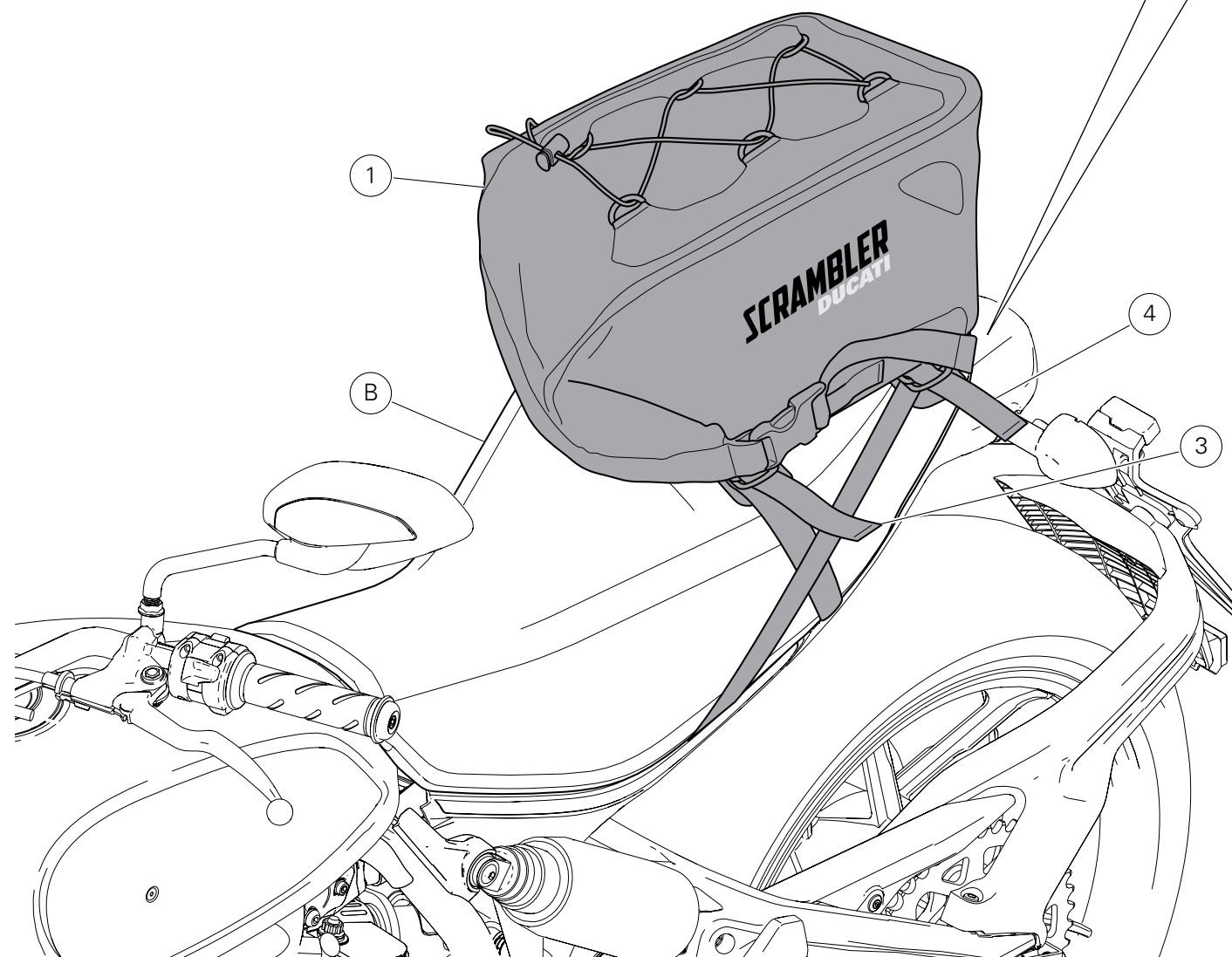
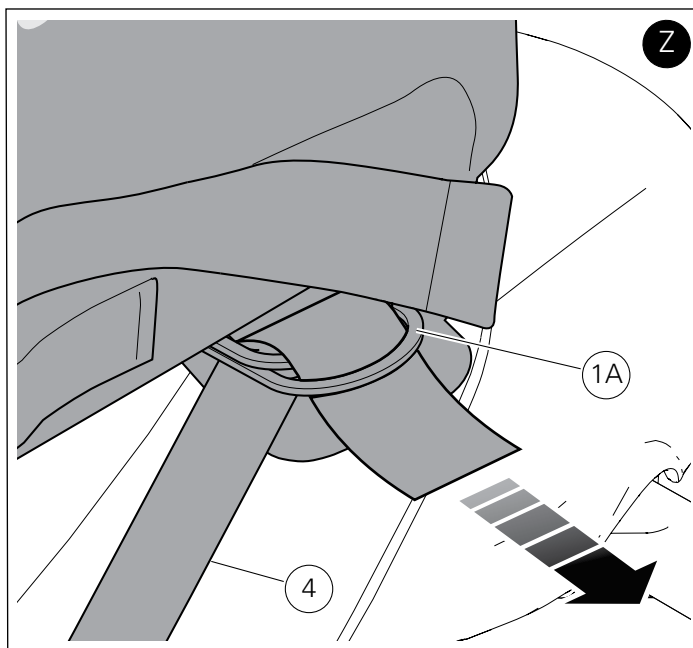
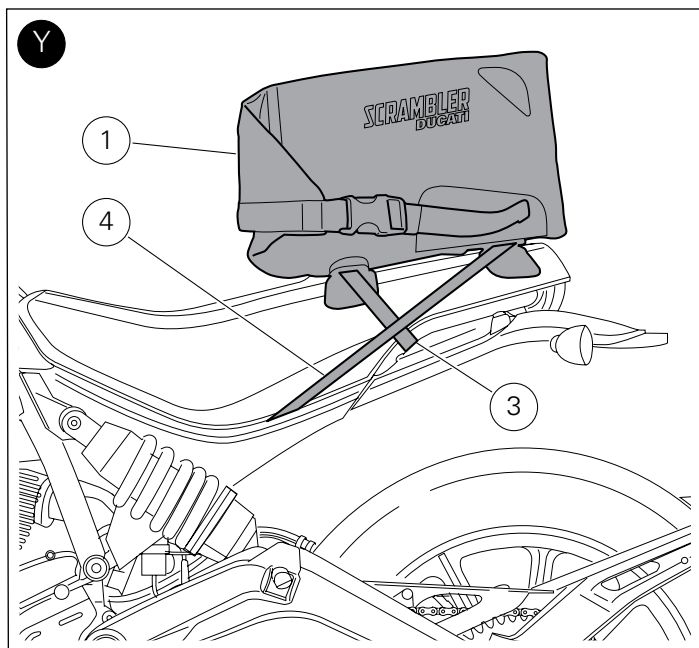

Apoie a bolsa para assento (1) no assento (B), na posição correta. Fixe a bolsa para assento (1) inserindo os cintos de segurança curtos (3) e compridos (4) nas específicas fivelas (1A), conforme indicado na figura (Z).



### Importante

Para um correta fixação da bolsa para assento (1) os cintos de segurança curtos (3) devem ser inseridos nas fivelas anteriores da bolsa, enquanto os cintos de segurança compridos (4) devem ser inseridos nas fivelas posteriores.

Por conseguinte é necessário que os cintos estejam cruzados entre si, conforme mostrado na figura (Y).

Puxe com força as extremidades das n.4 tiras de segurança (3) e (4), para garantir a fixação da bolsa ao assento.

Recolha as extremidades das tiras de maneira adequada.

É possível utilizar a bolsa para assento (1) como mochila, utilizando a específica bandoleira (2).



### Atenção

Controle periodicamente a integridade das tiras de segurança.



### Atenção

Antes de iniciar uma viagem, certifique-se de que as tiras de segurança estejam sempre engatadas na bolsa (1) e esticadas, a fim de evitar a separação da própria bolsa da moto durante a fase de marcha.



### Atenção

É obrigatório respeitar os limites de velocidade impostos pelo país onde circula com a moto e, de qualquer maneira, é proibido ultrapassar os 130 Km/h com a bolsa (1) para assento montada na moto, pois, para além dessa velocidade, corre-se o risco de separação da bolsa.



### Importante

A contínua e prolongada exposição aos agentes atmosféricos pode causar mínimas ou sensíveis mudanças na cor dos tecidos/materiais.



### Atenção

O peso máximo transportável pela bolsa (1) é de 5 Kg. Se exceder o peso aconselhado, risca-se o rompimento da bolsa, que pode influenciar negativamente a segurança do condutor.

Quando efetuar a lavagem da moto, será necessário remover a bolsa do assento (1).

## Verificações

Verifique se a bolsa para assento (1) está fixada firmemente ao chassi (C).

Set seat bag (1) on seat (B) in the proper position.

Fix seat bag (1) by inserting the short (3) and long (4) safety belts inside the special buckles (1A), as shown in the figure (Z).



### Caution

For a correct fastening of seat bag (1) the short (3) and long (4) safety belts must be respectively inserted inside the front and rear buckles of the bag.

As a result, belts must be crossed to each other as shown in the figure (Y).

Pull hard the ends of the 4 safety belts (3) and (4) to ensure the fastening of the bag to the seat.

Gather the belts ends in a proper way.

It is possible to use the seat bag (1) as a rucksack by using the special shoulder strap (2).



### Warning

Periodically check the integrity of the safety belts.



### Warning

Before riding, make sure safety belts are always fastened to bag (1) and tensioned so as to prevent the bag from releasing from motorcycle while riding.



### Warning

You are required to strictly comply with the speed limits of the country where you are riding; in any case, never exceed 130 Km/h when the seat bag (1) is installed to the bike or the bag could detach.



### Caution

Continuous and prolonged exposure to weather may create minor discoloration in the fabrics/materials.



### Warning

Maximum load that can be carried by the seat bag (1) is 5 Kg. Do not exceed this limit or the bag might break thus jeopardizing rider safety.

When washing the motorcycle, always remove the seat bag (1).

## Checks

Check that seat bag (1) is securely attached to the frame (C).

# NOTAS / NOTES

Lined area for notes, consisting of numerous horizontal dotted lines for writing.



## Kit bolsa de asiento estanca OUTDOOR / アウトドアシート用防水バッグキット



## Símbolos

Para una lectura rápida y racional se han empleado símbolos que evidencian situaciones de máxima atención, consejos prácticos o simples informaciones. Prestar mucha atención al significado de los símbolos porque su función consiste en omitir la repetición de conceptos técnicos o advertencias de seguridad. Los símbolos deben considerarse como verdaderos "apuntes". Consultar esta página cada vez que se tengan dudas sobre su significado.



### Atención

El incumplimiento de las instrucciones indicadas puede crear una situación de peligro y ocasionar graves lesiones e incluso la muerte.



### Importante

Indica la posibilidad de provocar un daño al vehículo y/o a sus componentes si no se siguen las instrucciones indicadas.



### Notas

Suministra útiles informaciones sobre la operación en curso.

## Referencias

Las partes resaltadas en gris y la referencia numérica (Por ej. ①) representan el accesorio que se debe instalar y los eventuales componentes de montaje suministrados en el kit.

Las partes con referencia alfabética (Por ej. Ⓐ) representan los componentes originales presentes en la motocicleta.

Todas las indicaciones derecha o izquierda se refieren al sentido de marcha de la motocicleta.

## Advertencias generales



### Atención

Las operaciones descritas en las siguientes páginas deben realizarse correctamente para no perjudicar la seguridad del piloto.



### Atención

Las operaciones descritas en las siguientes páginas deben realizarse correctamente para no perjudicar la seguridad del piloto.



### Notas

La documentación necesaria para realizar el montaje del Kit es el: MANUAL DE TALLER, relativo al modelo de moto en vuestro poder.



### Notas

Si fuera necesario sustituir un componente del kit, consultar la tabla de recambios adjunta.

## シンボル

素早くかつ合理的に読み進めることができるように、本マニュアルではいくつかのシンボルを導入し、最大限の注意を払う必要がある状況や、推奨事項、または一般情報を明確にしています。技術的概念や安全に関する警告を繰り返し記載する必要がないように機能しているので、各シンボルの意味に十分注意してください。シンボルは、実際上の“覚え書き”であると考えてください。シンボルなどの意味がわからなくなったり疑問に思う場合は、必ずこのページで調べるようにしてください。



### 注記

この説明書に従わずに使用すると危険な状況を招き、重大なけが、あるいは死をももたらす原因となることがあります。



### 重要

この説明書に従わずに使用すると、車体及び/ 又はその部品に損害を招く可能性があります



### 参考

操作中の内容に関する有用な情報を掲載しています。

## 参照

灰色で表示する部品、および参照番号 (Es. ①) で表示する部品は、キットに付属する取り付け部品および組み立て部品を示します。

参照アルファベット (Es. Ⓐ) で表示する部品は、車両に付属するオリジナル部品を示します。

すべての右及び左の指示は車体の進行方向を向いたものです。

## 一般警告事項



### 警告

以下のページに記載されている作業が規定通りに実施されないと、ライダーの安全性を脅かすおそれがあります。



### 警告

以下のページに記載されている作業が規定通りに実施されないと、ライダーの安全性を脅かすおそれがあります。



### 参考

キットの取り付けに必要な資料：お手持ちの車両モデルに対応するワークショップマニュアル。



### 参考

キットの部品を交換する必要がある場合は、添付のスペアパーツ表を参照してください。

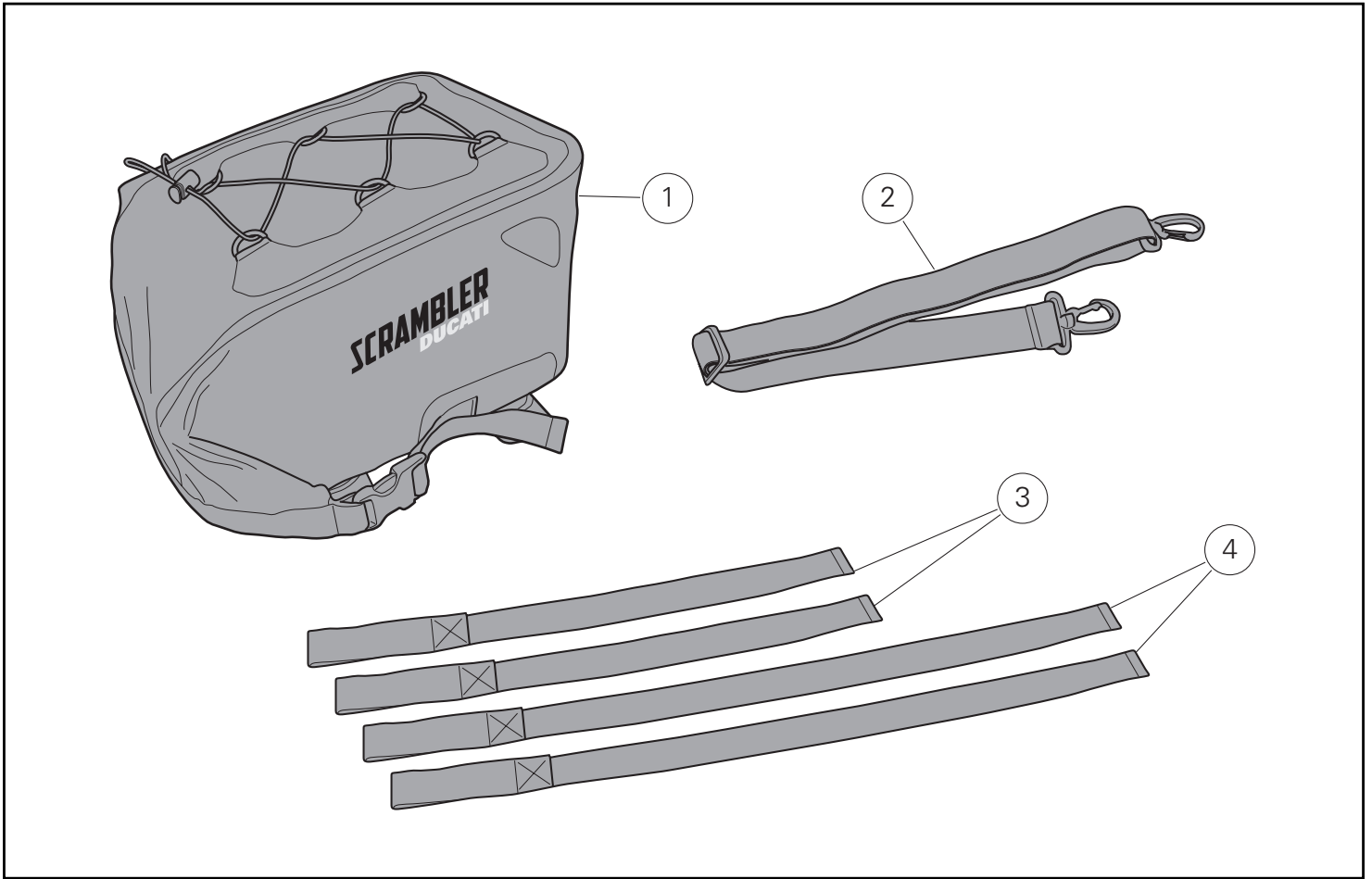

Pos.	Denominacion	説明
1	Bolsa asiento	シートバッグ
2	Tirante	ショルダーストラップ
3	Correa de seguridad cortas	ショートセーフティベルト
4	Correa de seguridad largas	ロングセーフティベルト

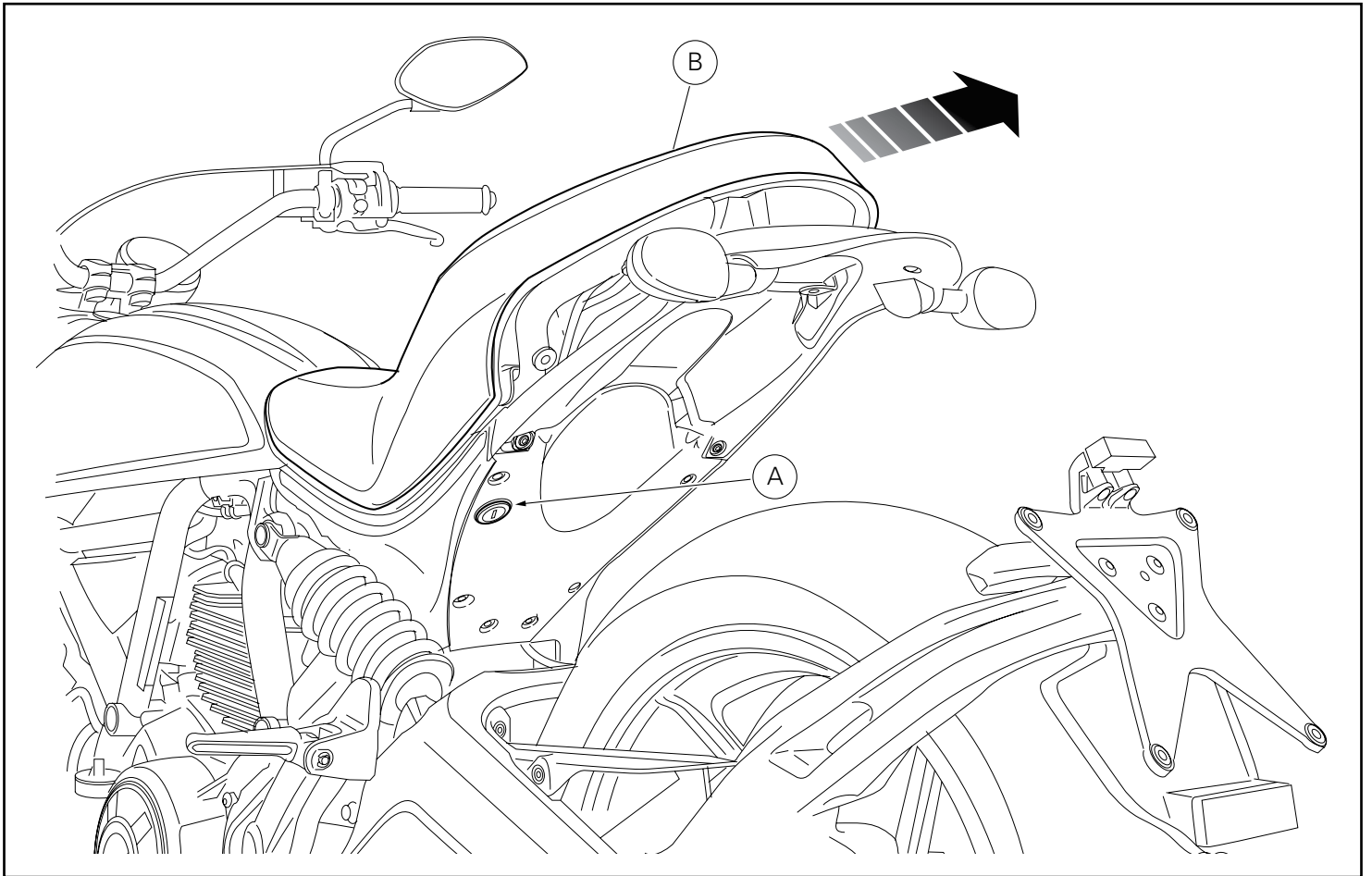

### Desmontaje componentes originales

Introducir la llave en la cerradura (A), girarla en el sentido de las agujas del reloj y contemporáneamente presionar hacia abajo cerca del pestillo para facilitar el desenganche del perno.  
Extraer el asiento (B) de los seguros delanteros, tirándolo hacia atrás.

### オリジナル部品の取り外し

キーを鍵穴 (A) に差し込み、時計周りに回します。同時に、ピンを外しやすくするために掛け金の近くを下に押し下げます。フロントストッパーからシート (B) を後ろ側へ引き出します。

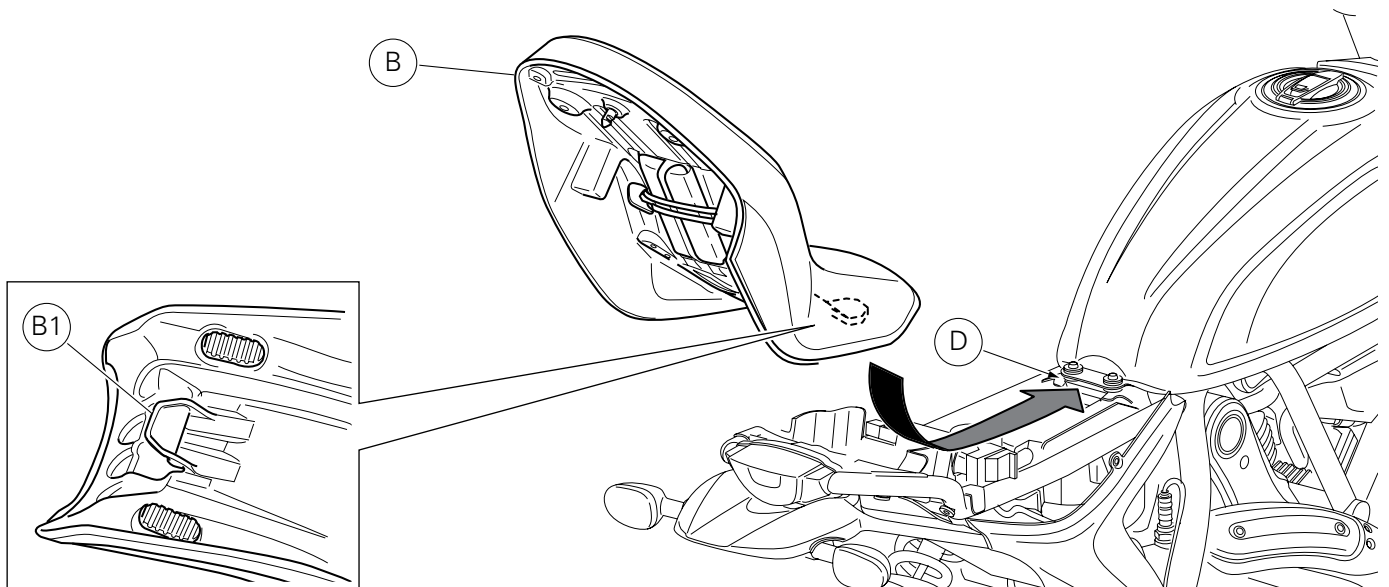
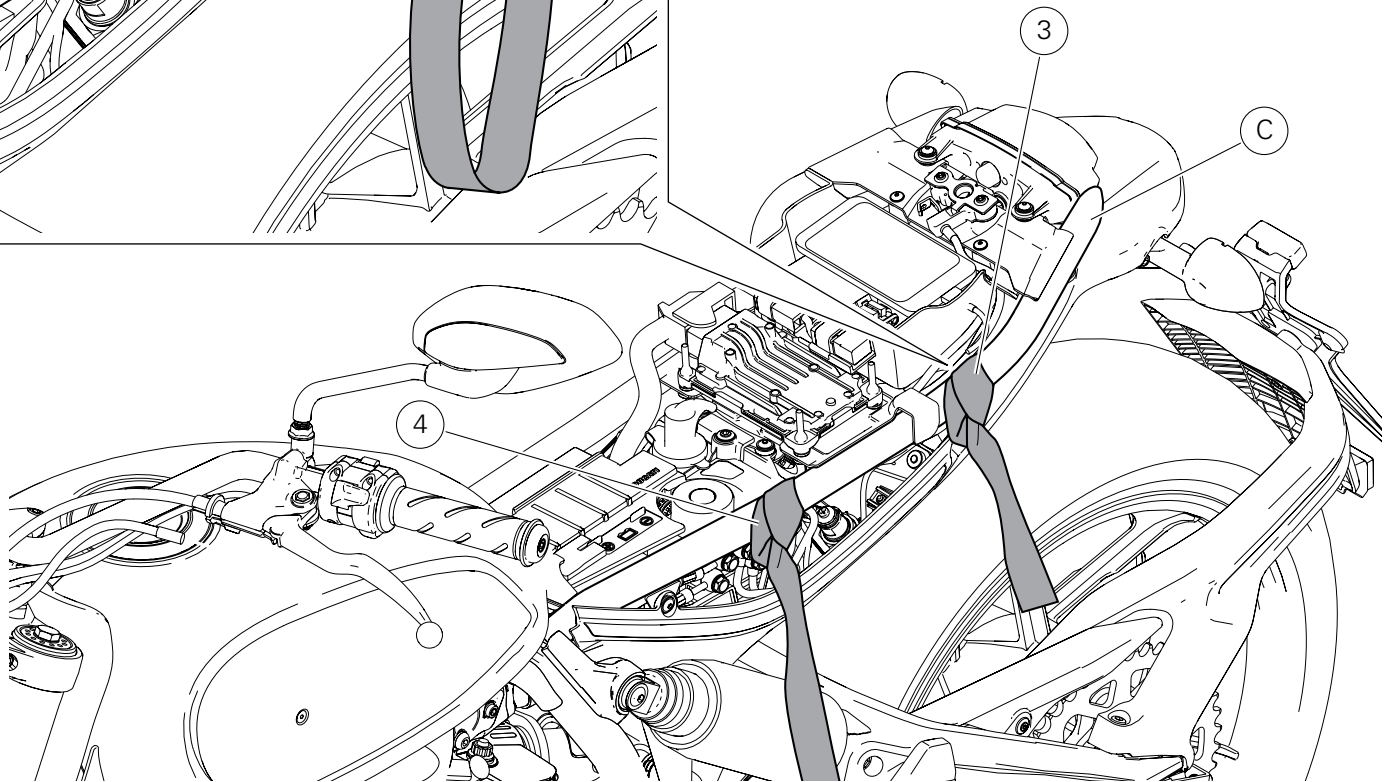
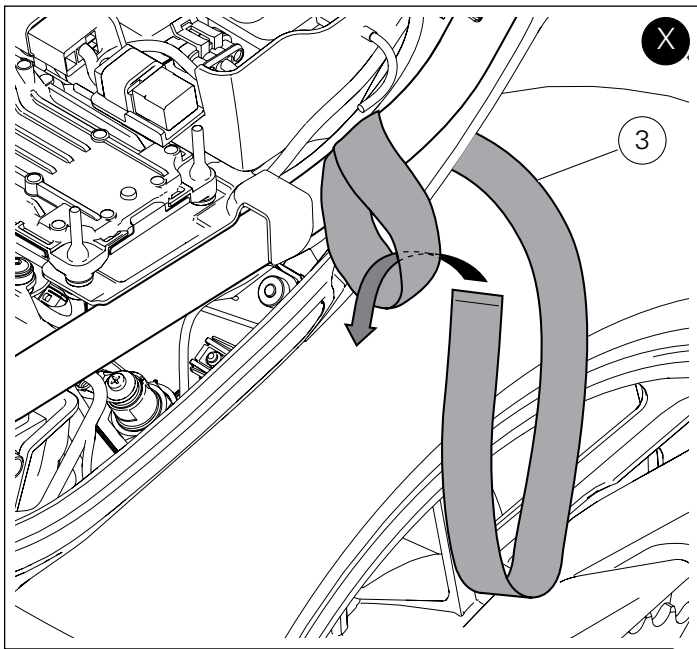

## Montaje componentes kit



### Importante

Controlar, antes del montaje, que todos los componentes se encuentren limpios y en perfecto estado.  
Adoptar todas las precauciones necesarias para evitar daños en la superficie exterior de los componentes donde se debe operar.

Operando desde el lado izquierdo de la motocicleta, fijar la correa de seguridad corta (3) en la parte trasera del bastidor (C), mientras que la larga (4) en la parte delantera. Para fijar las dos correas de seguridad realizar un nudo (boca de lobo) como se indica en la figura (X).

Repetir la misma operación para el lado derecho de la motocicleta.

Asegurarse de que todos los elementos se encuentren correctamente dispuestos y fijados en el compartimiento debajo del asiento.

Introducir el extremo delantero (B1) del fondo asiento debajo del alojamiento (D) del soporte bastidor.

Empujar el extremo trasero del asiento (B) hasta escuchar el clic del pestillo de la cerradura.

Asegurarse de que el asiento se encuentre fijado firmemente al bastidor y quitar la llave de la cerradura.

## キット部品の取り付け



### 重要

取り付け前にすべての部品に汚れがなく、完璧な状態であることを確認します。作業する部品の外側表面を傷つけないために、必要な予防措置を取ってください

車両の左側から作業します。ショートセーフティベルト (3) をフレーム (C) の後部に、ロングセーフティベルト (4) をフレームの前部に固定します。2本のセーフティベルトを固定するには、図 (X) のように結び目 (ひばり結び) を作ります。車両の右側についても同様の作業を繰り返します。

すべてのエレメントが正しい位置にあり、シート下に固定されていることを確認します。

シート底部の前端部 (B1) をフレームマウントの取り付け位置 (D) の下に挿入します。

シート (B) の最後部をロックの掛け金がカチッとなるまで押しませす。

シートがフレームにしっかりと固定されたことを確認し、鍵穴からキーを抜きます。

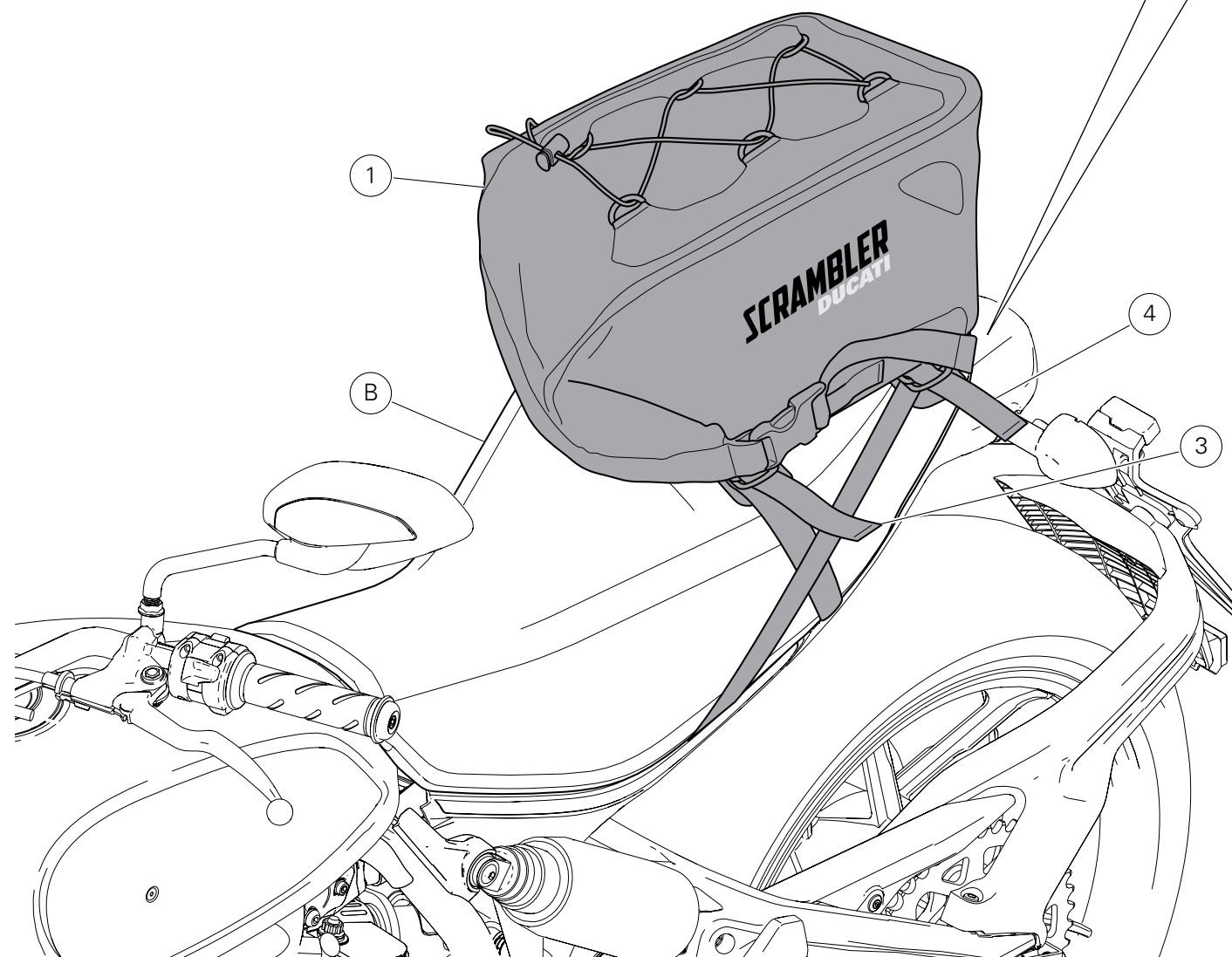
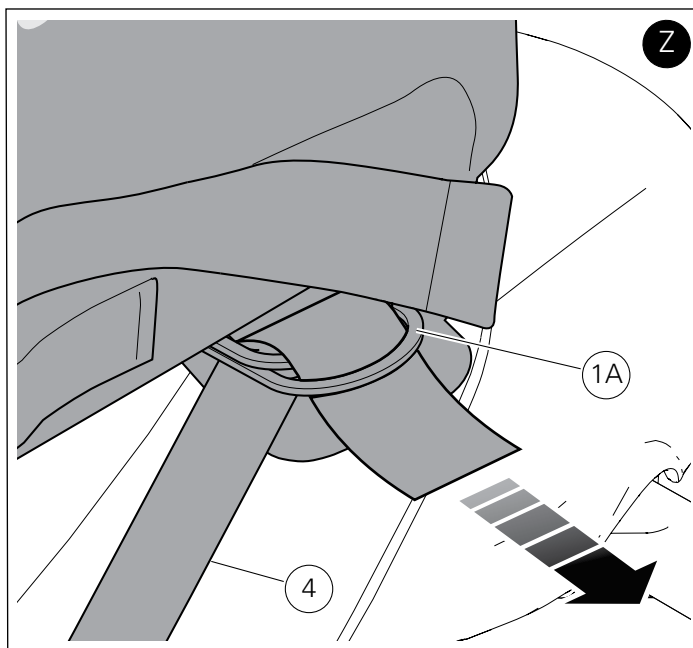
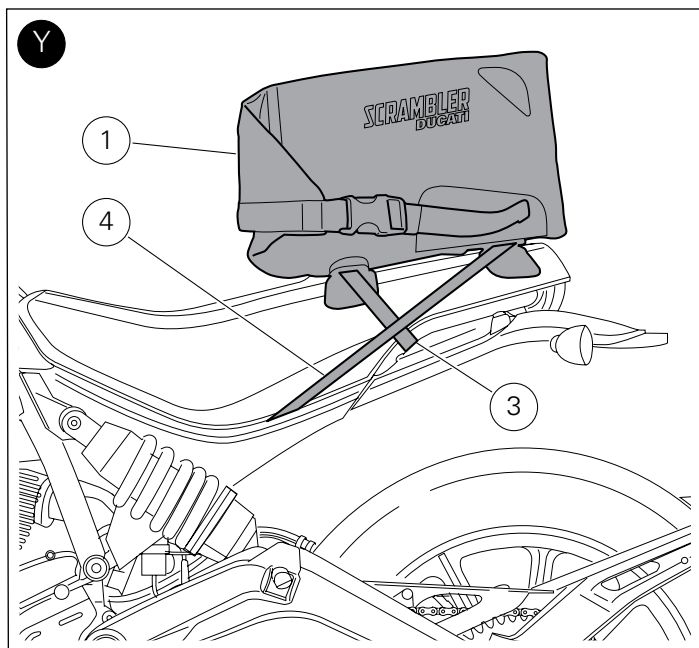

Apoyar la bolsa asiento (1) sobre el asiento (B) en la posición correcta.

Fijar la bolsa asiento (1) introduciendo las correas de seguridad cortas (3) y largas (4) en las específicas hebillas (1A), como se indica en la figura (Z).



### Importante

Para una correcta fijación de las bolsas asiento (1) las correas de seguridad cortas (3) se deben introducir en las hebillas delanteras de la bolsa, mientras que las correas de seguridad largas (4) se deben introducir en las hebillas traseras.

En consecuencia, es necesario que las correas se crucen entre ellas, como ilustra la figura (Y).

Tirar con fuerza de los extremos de las 4 correas de seguridad (3) y (4) para asegurar la fijación de la bolsa al asiento.

Recoger los extremos de las correas de manera adecuada.

Es posible utilizar la bolsa asiento (1) como mochila utilizando el específico tirante (2).



### Atención

Controlar periódicamente la integridad de las correas de seguridad.



### Atención

Antes de iniciar el viaje, asegurarse de que las correas de seguridad se encuentren siempre enganchadas a la bolsa (1) y tensadas para evitar que la bolsa se desprenda de la motocicleta durante la marcha.



### Atención

Es obligatorio respetar los límites de velocidad establecidos por el país donde se circula y de todas maneras se prohíbe superar los 130 Km/h con la bolsa (1) montada en la moto porque se corre el riesgo que la misma se desprenda del asiento.



### Importante

La continua y prolongada exposición a los agentes atmosféricos puede causar mínimamente o sensiblemente cambios en el color del tejido/material.



### Atención

El peso máximo que se puede transportar en la bolsa (1) es de 5 Kg. En el caso que se exceda el peso recomendado, se corre el riesgo que se rompa la bolsa, esto puede afectar de manera negativa la seguridad del piloto.

Cuando se lava la moto es necesario extraer la bolsa del asiento (1).

## Controles

Controlar que la bolsa asiento (1) se encuentre fijada de manera firme al bastidor (C).

シートのシートバッグ (1) をシート (B) の正しい位置に置きます。図 (Z) のように、ショートセーフティベルト (3) およびロングセーフティベルト (4) を所定のバックル (1A) に挿入し、シートバッグ (1) を固定します。



### 重要

シートバッグ (1) を正しく固定するには、ショートセーフティベルト (3) をバッグのフロントバックルに、ロングセーフティベルト (4) をリアバックルに挿入します。

したがって、図 (Y) のようにベルト同士が交差します。

4本のセーフティベルト (3) および (4) の両端を力いっぱい引っ張り、バッグをシートにしっかりと固定させます。ベルトの両端を適切にまとめます。

シートバッグ (1) は所定のショルダーストラップ (2) を取り付けることでリュックとして使用することができます。



### 注記

セーフティベルトに傷や損傷等がないことを定期的に確認してください。



### 注記

走行中に車両からバッグが外れないよう、ツーリング前に必ずセーフティベルトをバッグ (1) に留め、ピンと張っていることを必ず確認してください。



### 注記

運転する国で定められた制限速度を守らなければなりません、いずれにせよ、シートからバッグが外れる危険があるので、車両にバッグを取り付けた状態では130 Km/h を超えてはなりません。



### 重要

長期間にわたり連続して大気にさらすと、生地/素材の色が若干変化することがあります。



### 注記

バッグの最大輸送重量は5Kg です。推奨重量を超えた場合、バッグ自体が損壊する危険があり、ライダーの安全性に影響を及ぼす可能性があります。

車両を洗浄する際、シートバッグ (1) を取り外す必要があります。

## 確認

シートバッグ (1) がフレーム (C) にしっかりと固定されていることを確認します。



**DUCATI** PERFORMANCE accessories

## レース専用部品 ご注文書

### ご注文商品

1 P/N

商品名

2 P/N

商品名

3 P/N

商品名

4 P/N

商品名

5 P/N

商品名

### お客様ご記入欄

私は上記レース専用部品を下記車両に装着し、サーキット走行のみに利用し、一般公道には利用しません。

車台番号 ZDM

モデル名

お客様署名

ご注文日

### ドゥカティ正規ネットワーク店記入欄

お客様に上記レース専用部品を販売し、レース専用部品のご利用方法を説明いたしました。

販売店署名

販売日

年

月

日

販売店様へお願い

- 上記ご記入の上、弊社アフターセールス部までFAXしてください。FAX:03-6692-1317
- 取り付け車両1台に1枚でご使用ください。